

NAME OF CONTRACTOR _____

PROPOSAL AND SPECIFICATIONS

FOR

HIGHWAY CONSTRUCTION

COUNTY LOCAL ROAD SYSTEM

**Do Not Separate
or Remove Sheets
From This Proposal**

PROJECT NO. LH 400016– Culvert replacement including grade establishment, sand subbase, aggregate base, HMA paving, gravel shoulders, and restoration on 116th Avenue approximately 3,950 feet east of 56th Street in Clyde Township, Allegan County.

CLYDE TOWNSHIP

October 14, 2020

BOARD OF COUNTY ROAD COMMISSIONERS
OF ALLEGAN COUNTY, MICHIGAN

1308 Lincoln Road, Allegan, MI 49010

ALLEGAN COUNTY ROAD COMMISSION
ADVERTISEMENT FOR BIDS
COUNTY LOCAL ROAD CONSTRUCTION

Sealed bids will be received by the Allegan County Road Commission at their office at 1308 Lincoln Road (M-89), Allegan, Michigan until 11:00 A.M., Local Time, October 14, 2020, and, at such time, be publicly opened and read aloud for the following:

PROJECT NO. LH 400016– Culvert replacement including grade establishment, sand subbase, aggregate base, HMA paving, gravel shoulders, and restoration on 116th Avenue approximately 3,950 feet east of 56th Street in Clyde Township, Allegan County.

Complete specifications, plans, and bid forms are available at the Road Commission office and the Road Commission website www.alleganroads.org under the Projects link. When accessing plans from the website, please send an email to jscott@alleganroads.org to be added to the plan holders list.

All bids must be submitted on forms furnished by the Road Commission and sealed in envelopes with the name and address of the bidder, and the item bid upon clearly marked thereon.

A bid deposit of at least 5% of the bid amount will be required for this item. The bid deposit may be in the form of certified check, cashier's check or bid bond.

The Commission reserves the right to reject any or all bids, to waive minor technicalities, and to accept the bid that is deemed to be in the best interest of the County of Allegan.

BOARD OF COUNTY ROAD COMMISSIONERS
OF ALLEGAN COUNTY, MICHIGAN

John Kleinheksel, Chairman
James Rybicki, Vice-Chairman
Larry Brown, Member

PROJECT NO. LH 400016– Culvert replacement including grade establishment, sand subbase, aggregate base, HMA paving, gravel shoulders, and restoration on 116th Avenue approximately 3,950 feet east of 56th Street in Clyde Township, Allegan County.

BID and AWARD

Date_____

Board of County Road Commissioners
Of Allegan County
1308 Lincoln Road
Allegan, MI 49010

Gentlemen:

The undersigned has examined the plans, specifications, and location of the work described herein and is fully informed as to the nature of the work and the conditions relating to its performance and understands that the quantities shown in the estimate are approximate only and are subject to either increase or decrease; and hereby proposed to furnish all necessary machinery, tools, apparatus and other means of doing the work, do all the work, furnish all the materials except as otherwise specified herein, and, for the unit prices named in the accompanying unit price schedule, to complete work in strict accordance with the plans and specifications therefore.

The undersigned further proposes to such extra work as may be ordered by you, prices for that are not included in the itemized bid, compensation therefore to be made on the basis agreed upon before such extra work is begun.

The undersigned agrees to complete all items of work on or before May 31, 2021. If the precast concrete box culvert is installed during a time that asphalt plants are closed, the road will be brought to grade with HMA millings and then paved in the spring of 2021. The schedule for liquidated damages is located in the general specifications.

The contractor shall submit a progress schedule subject to approval of the Engineer prior to the award of the contract.

The undersigned encloses a certified check, cashier's check, or Bid Bond, representing 5% of the bid, in the amount of \$_____, payable to the Allegan County Road Commission as a guarantee of good faith. If the contract is awarded to the undersigned, and the undersigned fails to furnish satisfactory bonds to the Road Commission within fifteen (15) days after being given notice of award said check will be forfeited to the Allegan County Road Commission as liquidated damage.

THE CONTRACT

The Contract Documents consist of the bid documents, this Agreement, Conditions of the Contract (General Supplementary, Special and other Conditions), Drawings, Specifications, Addenda issued prior to execution of this Agreement, other documents listed in this Agreement and Modifications issued after execution of this Agreement; these form the Contract, and are as fully a part of the Contract as if attached to this Agreement or repeated herein. The Contract represents the entire and integrated agreement between the parties hereto and supersedes prior negotiation, representations or agreements, either written or oral. If anything in the other Contract Documents is inconsistent with this Agreement, this Agreement will govern.

PROJECT NO. LH 400016– Culvert replacement including grade establishment, sand subbase, aggregate base, HMA paving, gravel shoulders, and restoration on 116th Avenue approximately 3,950 feet east of 56th Street in Clyde Township, Allegan County.

ALLEGAN COUNTY ROAD COMMISSION
ALLEGAN, MICHIGAN
ITEMIZED UNIT PRICE BID SCHEDULE

ITEM OF WORK	QUANTITY	UNIT	UNIT PRICE	TOTAL
Clearing	1	LS		
Station Grading	1	LS		
Subbase, CIP	250	Cyd		
Topsoil Surface, Salv, LM	60	Cyd		
Geotextile Stabilization	500	Syd		
Aggregate, 6A	50	Ton		
Subgrade Undercutting, Type II	200	Cyd		
Precast Concrete Box Culvert, 12' x 7'	48	Ft		
Aggregate Base, 6 inch	425	Syd		
Shoulder, CI II	35	Ton		
HMA, LVSP	65	Ton		
Restoration	1	LS		
Extended Restoration	1	LS		
Seeding, Mixture CR	50	Lb		
Sign, Type B, Temp, Modified	126	Sft		
Plastic Drum, High Intensity, Ltd, Modified	20	Ea		
Barricade Type III, High Intensity, Dbl Sided, Ltd, Modified	6	Ea		
Riprap, Plain	60	Syd		
Mulch Blanket, High Velocity	300	Syd		
Erosion Control, Silt Fence	400	Ft		
Project Cleanup	1	LS		

TOTAL \$ _____

The undersigned bidder agrees that the following is a complete and accurate list of all sub-contractors to be utilized is awarded this contract and any change from this list will be permitted only with the consent of the Board of County Road Commissioners of Allegan County. **LIST NAME OF EACH SUB-CONTRACTOR AND BRIEF DESCRIPTION OF WORK TO BE DONE.**

I hereby state that all of the information I have provided is true, accurate and complete. I hereby state that I have the authority to submit this bid, which will become a binding contract if accepted by the Board of County Road Commissioners of Allegan County. I hereby state that I have not communicated with nor otherwise colluded with any other bidder, nor have I made any agreement with nor offered or accepted anything of value from an official or employee of the Board of County Road Commissioners of Allegan County that would tend to destroy or hinder free competition.

In case the bidder is a co-partnership, each member must sign this proposal.

In case the bidder is a Corporation, this proposal must be executed by its duly authorized officials in accordance with its articles of incorporation and a certified copy of such articles must be attached hereto.

I hereby state that I have read, understand and agree to be bound by all the terms of this bid document.

SIGNATURE: _____ NAME: _____
(Type or Print)

TITLE: _____ DATE: _____

FIRM NAME: _____ PHONE: _____

ADDRESS: _____
(Street Address) (City) (State) (Zip)

FOR COUNTY USE ONLY – DO NOT WRITE BELOW

ACCEPTED BY: BOARD OF COUNTY ROAD COMMISSIONERS
OF THE COUNTY OF ALLEGAN, MICHIGAN

Chairman

Vice-Chairman

Member

Date

STANDARD SPECIFICATIONS

The Standard Specifications for Construction of the Michigan Department of Transportation, 2012 Edition shall apply. Nothing herein will be construed to create any obligation or duty on the part of the Board of County Road Commissioners of Allegan County, including obligations or duties which may be expressed or implied in the Standard Specifications for Construction of the Michigan Department of Transportation, unless specifically set forth in the contract documents.

The quantity for all pay items will not exceed more than 5% of the plan quantity unless the contractor has received a written work order from the Allegan County Road Commission. Amounts in excess of the plan quantity will not be considered for payment unless the increase was directed by the Engineer or an error in calculations is proven.

CLEARING: The contractor will remove all trees and brush that are marked or are entirely or partially within the right-of-way or within the slope stake line as shown on the plans and all stumps within five (5) feet of the right-of-way or within the slope stake line unless instructed otherwise by the Engineer. Trees will remain the property of the adjacent landowner, if they want them. If not, the contractor will dispose of them. The contractor will dispose of all stumps. Where called for on the plans or when directed by the Engineer in the field, the contractor shall grind stumps to avoid disturbing underground facilities. The tree and stump removal will be done in accordance with Section 201 & 202 of the 2012 Standard Specifications for Construction.

The Contractor will not receive any additional compensation due to delays caused by utility companies.

METHOD OF PAYMENT FOR CLEARING: The item of "Clearing" will be paid for as a lump sum. No tree count is provided. It is the contractor's responsibility to inspect the site and verify accuracy of trees, stumps, and brush shown on the plans. No change in payment will be made for variances. Clearing stakes have been set. Direct any questions to the Allegan County Road Commission.

<u>PAY ITEM</u>	<u>PAY UNIT</u>
Clearing	Lump Sum

STATION GRADING: The item of "Station Grading" will include all culvert removal, fence removal, fence relocation regardless of fence type, obliterating roadway, rock excavation, concrete removal, HMA removal, guardrail removal, earth excavation, embankment, and saw cuts required. The contractor will place ditches and slopes as shown on the project cross section sheets. The earth excavation quantity does include the existing topsoil and pavement that must be stripped. The embankment quantity does include material to replace stripped topsoil and pavement in fill sections. The embankment quantity does not reflect shrinkage. Some excavation and embankment will be required to make a smooth transition into driveways; this is included in the earthwork figures. Additional driveway changes in slopes or ditch depths will not result in extra payment on this item. Additional grading in yards at the request of property owners will be included in Station Grading.

Some material excavated from ditches will not be suitable for embankment and will be disposed of at the contractor's expense.

All slopes in yard areas will be finished to Class A tolerance. Slopes not in yards will be trimmed to Class B tolerance (Section 205.03 page 138).

The Controlled Density Method (Section 205.03 page 135) of the Standard Specifications for Construction will apply. The Engineer will run density tests at his discretion.

Any salvaged gravel or HMA millings required to maintain local traffic will be included in the item of Station Grading.

STATION GRADING (CONT.):

The following is an approximate list of earthwork quantities (Note: Quantities below are compacted in place units, Subbase not included).

<u>STATION</u> 116 th Avenue	<u>EARTH EXCAVATION</u> 100 CYD	<u>EMBANKMENT</u> 150 CYD
--	------------------------------------	------------------------------

METHOD OF PAYMENT FOR STATION GRADING: The item of “Station Grading” will be paid for as a lump sum. The quantities listed above are approximate; any changes in quantity will not alter the lump sum pay quantity for Station Grading.

<u>PAY ITEM</u>	<u>PAY UNIT</u>
Station Grading	Lump Sum

SUBBASE, CIP: Section 301 of the Standard Specifications will apply. The contractor will furnish, place, compact and shape the material to obtain a minimum depth of 12 inch of Subbase for the length of the project. All Subbase will be Class II material.

The Subbase material will be compacted to not less than 95% of the maximum unit weight. Density tests will be done at the discretion of the Engineer.

METHOD OF PAYMENT FOR SUBBASE, CIP: The item of “Subbase, CIP” will be paid by the cubic yard, compacted-in-place.

<u>PAY ITEM</u>	<u>PAY UNIT</u>
Subbase, CIP	Cubic Yard

TOPSOIL SURFACE, SALV, LM: The existing topsoil will be stripped from the areas within the right-of-way or grading limits shown or as directed in the field, adjacent to roadway as detailed in the project description. The salvaged topsoil will be stockpiled for measurement. The item includes picking up, stockpiling, replacing and shaping the topsoil at least 3 inches deep.

Prior to seeding, the Contractor will be required to drag all front and back slopes that are 1 on 3 or flatter. Slopes that are steeper than 1 on 3 must be left in a relatively smooth condition. Slope preparation will be included in the item of Topsoil Surface, Salv, LM.

METHOD OF PAYMENT FOR TOPSOIL SURFACE, SALV, LM: The item of “Topsoil Surface, Salv, LM” will be paid for by the cubic yard as measured in the stockpile. The plan quantity is the maximum Cubic Yards that will be paid.

<u>PAY ITEM</u>	<u>PAY UNIT</u>
Topsoil Surface, Salv, LM	Cubic Yard

GEOTEXTILE, STABILIZATION: The item of “Geotextile, Stabilization” will include all labor, material and equipment to place material as instructed by the Engineer. Material will be in accordance with section 308 of the Standard Specifications.

METHOD OF PAYMENT FOR GEOTEXTILE, STABILIZATION: The item of “Geotextile, Stabilization” will be paid for by the square yard as measured in place.

<u>PAY ITEM</u>	<u>PAY UNIT</u>
Geotextile Stabilization	Square Yard

AGGREGATE, 6A: The item of “Aggregate, 6A” will include furnishing, hauling, placing, and shaping of the material. Material will meet MDOT 6A Specifications. This item is not shown on the plans, and will be used at the discretion of the Engineer. The item is intended to be used for pipe bedding over Geotextile Stabilization (separate item).

METHOD OF PAYMENT FOR AGGREGATE, 6A: The item of “Aggregate, 6A” will be paid for by the ton. Weight slips will be required.

<u>PAY ITEM</u>	<u>PAY UNIT</u>
Aggregate, 6A	Ton

SUBGRADE UNDERCUTTING, TYPE II: The item of “Subgrade Undercutting, Type II” will consist of cutting out undesirable material below the Subgrade and will include backfilling with Class II material (Section 205 Standard Specifications for Construction). Subgrade undercutting will be done only if requested by the Engineer. Backfill of Subgrade Undercutting will be compacted to not less than 95% of the Maximum Unit Weight. Tests will be run at the discretion of the Engineer. This item will also include all muck, morrow and peat excavation and backfill required up to 6 feet deep.

METHOD OF PAYMENT FOR SUBGRADE UNDERCUTTING, TYPE II: The item of “Subgrade Undercutting, Type II” will be paid for by the cubic yard as measured from the area actually excavated from the roadway. Backfill for the undercutting is included in the price for Subgrade Undercutting, Type II.

<u>PAY ITEM</u>	<u>PAY UNIT</u>
Subgrade Undercutting, Type II	Cubic Yard

PRECAST CONCRETE BOX CULVERT: The item of “Precast Concrete Box Culvert” will include all labor, material, and equipment necessary to provide and install the precast concrete box culvert as shown on the plans. The Contractor will furnish the culvert and precast footings. This work shall be done in accordance with the requirements of Sections 406, 701 and 909 of the 2012 Michigan Department of Transportation Standard Specifications for Construction and as specified herein. The work of “Precast Concrete Box Culvert” shall consist of the following:

- Providing and installing the precast concrete box culvert and footings as shown on the plans.
- Installing all grout, joint sealers, shims, gaskets, geotextile wrap, inserts and underdrain required.
- Dewatering the area to allow construction of the footings and culvert.
- Maintaining stream flow during construction.

PRECAST CONCRETE BOX CULVERT (CONT.):

- Performing the channel excavation as shown on the plans and as directed by the engineer including required stream relocation and backfill of abandoned stream channel.
- Performing any excavation or backfill that is required due to the type of culvert provided.
- Furnishing, excavating for, placing geotextile stabilization, and placing and grading 6A bedding stone up to 2' deep and 2' wider than the culvert as required.
- Furnishing, placing and compacting structure backfill. (est. 550 Cyd)

METHOD OF PAYMENT FOR PRECAST CONCRETE BOX CULVERT: The item of "Precast Concrete Box Culvert" will be paid for by the linear foot.

<u>PAY ITEM</u>	<u>PAY UNIT</u>
Precast Concrete Box Culvert, 12' x 7'	Foot

AGGREGATE BASE, 6 INCH: The item of "Aggregate Base, 6 inch" will include all labor, material and equipment to place, and compact the base course.

The contractor may use 22A gravel, 22A slag, 22A limestone, 22A recycled concrete, or cold-milled bituminous material, which approximates the gradation for 22A material. When milled bituminous material is used as aggregate base, the density provisions of Standard Specifications are not waived. Milled bituminous material may be used full depth or on top of 22A gravel to obtain the specified thickness. 22A gravel shall not be placed on top of bituminous millings.

"Aggregate Base, 6 inch" must be placed directly on top of the sand subbase. Salvaged gravel or any material not meeting 22A specification is not allowed between the aggregate base and the sand subbase.

Section 302 of the Standard Specifications for Construction will apply

METHOD OF PAYMENT FOR AGGREGATE BASE, 6 INCH: The item of "Aggregate Base, 6 inch" will be paid for by the square yard, compacted in place.

<u>PAY ITEM</u>	<u>PAY UNIT</u>
Aggregate Base, 6 inch	Square Yard

SHOULDER, CL II: The item of "Shoulder, CI II" will include all labor, material and equipment to place and compact the material specified on the plans. Section 307 of the Standard Specifications for Construction will apply.

METHOD OF PAYMENT FOR SHOULDER, CL II: The item of "Shoulder, CI II" will be paid for by the ton. Weight slips will be required.

<u>PAY ITEM</u>	<u>PAY UNIT</u>
Shoulder, CI II	Ton

HMA

This item includes furnishing, hauling, and placing the required HMA mixture as indicated below. This work will also include cleaning and sweeping as required and placing mixes around catch basins and downspouts. No additional payment will be made for HMA valley curb. HMA material used on driveways, side roads, and intersections will also be included in this item and paid for as the HMA mixture used, no additional payment will be made. Driveway construction will be a single course over existing HMA approaches or over gravel approaches that connect to concrete drives inside or at the road right-of-way. Driveway construction will be two course on new road surfacing projects or where the concrete approach was removed. The work will also include furnishing and applying Bond Coat (included in HMA items), MDOT Standard Specifications MS-2a or SS-1h before placing the HMA. Bond Coat will be placed at the rate of 0.05 – 0.10 gallons per square yard prior to placing HMA.

Performance Grade Asphaltic Cement Bituminous Material will be PG 64-22 unless specified on the individual bid sheets as PG 64-28.

MIX DESIGNS

HMA, LVSP, MOD

1. The Contractor will submit a mix design with a range of 5.0 to 8.0 percent (effective bitumen) of bitumen content. Target air voids of 3.0% through regression.
2. The limits for the bitumen content of range 1 will be ± 0.30 from the optimum mix design.
3. The Contractor will submit a mix design and test results of the aggregates to be used at least two weeks before commencing paving. The mix design will be submitted to an approved testing laboratory for design compliance tests. The Road Commission will require a mix design in accordance with the MDOT "HMA Production Manual".
4. All mix designs must be approved by the Engineer.

ROLLING HMA

Number of Rollers Method shall apply as a minimum requirement for this project. The Nuclear Gage Method for testing compaction may be used at the discretion of the Engineer.

Number of Rollers Required Based on Placement Rate:

AVERAGE LAY DOWN RATE SQUARE YARDS PER HOUR	NUMBER OF ROLLERS REQUIRED	
	COMPACTION ROLLERS	FINISH ROLLERS
LESS THAN 800	1	*1
800 – 1,800	1	1
1,800 – 4000	2	1
4000 – 7000	3	1

*The compaction roller may be used as the finish roller also.

METHOD OF PAYMENT FOR HMA: The item of HMA will be paid for by the Ton.

PAY ITEM

PAY UNIT

HMA, LVSP, Mod

Ton

RESTORATION: The item of “Restoration” will include all labor, material and equipment required to do the restoration. Restoration will consist of placing Seeding, Mixture TUF (220#/acre); Fertilizer, Chemical Nutrient, CI A (176#/acre); Mulch (2 ton/acre); and Mulch Anchoring. Place Mulch and Mulch Anchoring within one calendar day after seeding.

Section 816 of the Standard Specifications for Construction will apply. The following is an approximate list of restoration material quantities:

<u>MATERIAL</u>	<u>QUANTITY</u>
Seeding, Mixture TUF	40 Lb
Fertilizer, Chemical Nutrient, CI A	30 Lb (Nutrients)
Mulch	N/A
Mulch Anchoring	N/A

METHOD OF PAYMENT FOR RESTORATION: The item of “Restoration” will be paid for as a lump sum.

<u>PAY ITEM</u>	<u>PAY UNIT</u>
Restoration	Lump Sum

EXTENDED RESTORATION: The item of “Extended Restoration” will include all labor, material and equipment required to maintain the restoration of the construction site. The contractor shall be responsible for the permanent establishment of turf and maintaining the temporary and permanent soil erosion control measures for a period of one year from the date of final approval or when the site is stabilized and approved by the Engineer. This may include reseeding, maintaining check dams and spillways, and fixing erosion on site.

METHOD OF PAYMENT FOR EXTENDED RESTORATION: The item of “Extended Restoration” will be paid for as a lump sum.

<u>PAY ITEM</u>	<u>PAY UNIT</u>
Extended Restoration	Lump Sum

SEEDING, MIXTURE CR: The item “Seeding, Mixture CR” will include all labor, material and equipment to place the seed as instructed by the Engineer. When directed by the Engineer, cereal rye seed will be placed at a rate of 70 pounds per acre.

METHOD OF PAYMENT FOR SEEDING, MIXTURE CR: The item of “Seeding, Mixture CR” will be paid for by the pound.

<u>PAY ITEM</u>	<u>PAY UNIT</u>
Seeding, Mixture CR	Pound

SIGN, TYPE B, TEMP, MODIFIED: The item of “Sign, Type B, Temp, Modified” will include supplying all materials, equipment and labor required to erect and maintain construction signs as designated by the Engineer. Materials and placement will conform to the MDOT Standard Specifications for Construction and the Michigan Manual of Uniform Traffic Control Devices. Signs will be placed as instructed by the Engineer. All “CONSTRUCTION AHEAD” and “ROAD CLOSED AHEAD” signs will be 48” x 48” mounted on two posts with one steady burn light. Place “CONSTRUCTION AHEAD” signs on all public roads approaching the project limits. Also, place “ROAD CLOSED AHEAD” signs at each end of the project limits if applicable. (Steady burn light and posts are included in the Sign, Type B, Temp, Modified item).

SIGN, TYPE B, TEMP, MODIFIED (CONT.):

METHOD OF PAYMENT FOR SIGN, TYPE B, TEMP, MODIFIED: The item of “Sign, Type B, Temp, Modified” will be paid for by the square foot of sign face.

<u>PAY ITEM</u>	<u>PAY UNIT</u>
Sign, Type B, Temp, Modified	Square Foot

PLASTIC DRUM, HIGH INTENSITY, LTD, MODIFIED: The item of “Plastic Drum, High Intensity, Ltd, Modified” will include all labor, equipment and material to furnish, set up, move and maintain the drums as required by the Engineer. Drums will be equipped with one light.

Section 812 of the Standard Specifications for Construction will apply.

METHOD OF PAYMENT FOR PLASTIC DRUM, HIGH INTENSITY, LTD, MODIFIED: The item of “Plastic Drum, High Intensity, Ltd, Modified” will be paid for by the individual unit.

<u>PAY ITEM</u>	<u>PAY UNIT</u>
Plastic Drum, High Intensity, Ltd, Modified	Each

BARRICADE ,TYPE III, HIGH INTENSITY, DOUBLE SIDED, LTD, MODIFIED: The item of “Barricade, Type III, High Intensity, Double Sided, Ltd, Modified” will include all labor, equipment and material to furnish, set up, move and maintain the barricades.

The Contractor will furnish and maintain Barricades, Type III with three lights and an R-11-4 Sign (ROAD CLOSED TO THRU TRAFFIC) mounted above the barricade. The R-11-4 sign will comply with and be paid as “Sign, Type B, Temp, Modified”.

Section 812 of the Standard Specifications for Construction will apply.

METHOD OF PAYMENT FOR BARRICADE, TYPE III, HIGH INTENSITY, DOUBLE SIDED, LTD, MODIFIED: The item of “Barricade, Type III, Double Sided, Ltd, Modified” will be paid for as individual units.

<u>PAY ITEM</u>	<u>PAY UNIT</u>
Barricade, Type III, High Intensity, Double Sided, Ltd, Modified	Each

RIPRAP, PLAIN: The item of “Riprap, Plain” will include all labor, equipment and material to place the Riprap as instructed by the engineer.

Section 813 of the Standard Specifications for Construction will apply to this item.

The Riprap will be placed over Geotextile Fabric, included in this item.

METHOD OF PAYMENT FOR RIPRAP, PLAIN: The item of “Riprap, Plain” will be paid for by the square yard. The pay quantity for this item shall not exceed more than 5% of the plan quantity unless the contractor has received a written work order from the Allegan County Road Commission. Amounts in excess of the plan quantity will not be considered for payment unless an error in calculations is proven.

<u>PAY ITEM</u>	<u>PAY UNIT</u>
Riprap, Heavy	Square Yard

MULCH BLANKET, HIGH VELOCITY: The item of “Mulch Blanket, High Velocity” will include all labor, material and equipment to place the blanket as instructed by the Engineer. Section 816 of the Standard Specifications for Construction will apply to this item.

The material for Mulch Blanket, High Velocity shall meet the specifications set on page 853 (Section 917.15) of the 2012 MDOT Standard Specifications for Construction.

The contractor will also seed following placement of Mulch Blanket, High Velocity with Seeding, Mixture TUF at the rate of 400 pounds per acre (included in this item).

METHOD OF PAYMENT FOR MULCH BLANKET, HIGH VELOCITY: The item of “Mulch Blanket, High Velocity” will be paid for by the square yard.

<u>PAY ITEM</u>	<u>PAY UNIT</u>
Mulch Blanket, High Velocity	Square Yard

EROSION CONTROL, SILT FENCE: The item of “Erosion Control, Silt Fence” will include all labor, material and equipment to place silt fence as instructed by the Engineer. Section 208 of the Standard Specifications for Construction will apply to this item.

METHOD OF PAYMENT FOR EROSION CONTROL, SILT FENCE: The item of “Erosion Control, Silt Fence” will be paid for by the linear foot.

<u>PAY ITEM</u>	<u>PAY UNIT</u>
Erosion Control, Silt Fence	Foot

PROJECT CLEANUP: The item of “Project Cleanup” will include all labor, material and equipment to pick up stone, sticks, branches, roots and other debris from the project.

This item will also include moving all mailboxes to a temporary location to be approved by the mail carrier and to reset the boxes permanently on the project. If new boxes or posts are required, they will be supplied by the Road Commission. Project Cleanup also includes placing a 1” x 3” with the respective property address written on it in the front yard of each residence to assist with identification for emergency vehicles.

METHOD OF PAYMENT FOR PROJECT CLEANUP: The item of “Project Cleanup” will be paid for as a lump sum.

<u>PAY ITEM</u>	<u>PAY UNIT</u>
Project Cleanup	Lump Sum

ALLEGAN COUNTY ROAD COMMISSION
ALLEGAN, MICHIGAN

GENERAL SPECIFICATIONS

MICHIGAN DEPARTMENT OF TRANSPORTATION-STANDARD SPECIFICATIONS

The work covered by the plans and specifications will be done in accordance with the 2012 Michigan Department of Transportation Standard Specifications for Construction, except as qualified in supplemental specifications and special conditions of the Allegan County Road Commission or as agreed to in writing at the time of the award of the contract.

DEFINITION OF TERMS

See Section 101 of Michigan Department of Transportation Standard Specifications for Construction.

SPECIAL CONDITIONS

Special requirements, regulations or directions applying to a particular project may be made a part of these specifications.

THE WORK

The work consists of the completed services, construction and/or paving by the Contract Documents and includes all materials and labor incorporated or to be incorporated therein.

RESPONSIBILITIES OF CONTRACTOR

A. Responsibility for and Supervision of Construction. Unless otherwise stated herein, Contractor will be solely responsible for all construction under this Contract, including the methods, techniques, sequences, procedures, and means, and for coordination of all work. Contractor will supervise and direct the work to the best of Contractor's ability, and give it all attention necessary for such proper supervision and direction. Contractor will notify the Road Commission of any anticipated pay item overruns or extras as soon as possible to allow for approval or design changes.

B. Discipline and Employment. Contractor will maintain at all times strict discipline among Contractor's employees, and contractor agrees not to employ for work on the project any person unfit for without sufficient skill to perform the job for which he or she was employed.

C. Furnishing of Labor, Materials, etc. Unless otherwise stated herein, Contractor will provide and pay for all labor, materials, and equipment, including tools, construction equipment, and machinery, utilities, including water, transportation, and all other facilities and services necessary for the proper completion of work on the project in accordance with the Contract Documents.

D. Payment of Taxes; Procurement of Licenses and Permits. Contractor will pay all taxes required by law in connection with work on the project in accordance with this agreement including sales, use, and similar taxes, and will secure all licenses and permits necessary for proper completion of the work, paying the fees for such licenses and permits.

E. Compliance with Laws and Regulations. Contractor will comply with all laws and ordinances, and the rules, regulations or orders of all public authorities relating to the performance of the work under and pursuant to this Agreement including, but not limited to, the Occupational Safety and Health Act of 1970, the Michigan Occupational Safety and Health Act, and the rules and regulations of the Michigan Construction Safety Commission.

RESPONSIBILITIES OF CONTRACTOR (CON'T):

F. Responsibility for Negligence of Employees and Subcontractors. Contractor assumes full responsibility for acts, negligence or omissions of all of Contractor's employees on the project, for those of Contractor's subcontractors and their employees, and for those of all other persons doing work under a contract with Contractor.

G. Responsibility for Safety. Unless otherwise stated herein, at Contractor's expense, Contractor will take all necessary precautions (including, without limitation, the furnishing of traffic control, barricades, traffic control devices, flaggers, warning lights, signs, warning signs, safety channels, channelization devices, guards, fences, walks, flags, cables and lights) for the safety of, and the prevention of injury, loss and damage to, persons and property (including, without limitation, in the term persons, members of the public, employees, Contractor's subcontractors and their respective employees, other contractors, their subcontractors and respective employees) on, about or adjacent to the location where the work is being performed, and will comply with all applicable provisions of safety rules, ordinances, codes, regulations, and orders of duly-constituted public authorities including, but not limited to, the Michigan Manual of Uniform Traffic Control Devices.

H. Responsibility of Subcontractors. The Contractor will require any subcontractor hired by the Contractor for the purpose of performing any of the work described by the Contract documents to be bound by all of the terms and conditions of the Contract documents and to perform the work in accordance with the Contract documents. Each and every condition of the Contract documents, including without limitation, the RESPONSIBILITIES OF THE CONTRACTOR, will be made a condition of each subcontract entered into by the Contractor in conjunction with the performance of the work.

INDEMNIFICATION

To the fullest extent permitted by law, the Contractor will indemnify, defend, and hold harmless The Board of County Road Commissioners of Allegan County, its officers, employees, representatives and agents from and against any and all claims, damages, demands, payments, suits, actions, recoveries, judgements, losses and expenses, including attorney fees, interest, and court costs, which are made, brought or recovered against the Board of County Road Commissioners of Allegan County, arising out of or resulting from performance of the Contractor's work under this Contract, provided that such claims, damages, losses, demands, payments, suits, actions, recoveries, judgements and/or expenses are attributable to bodily injury, sickness, disease or death, or to injury to or destruction of tangible property (other than the work itself) including loss of use resulting therefrom, but only if caused in whole or in part, by the act, omissions, fault, negligence or breach of the conditions of this Contract by negligent acts or omissions of the Contractor, the Contractor's sub-subcontractors, anyone directly or indirectly employed by them or anyone for whose acts they may be liable, regardless of whether or not such claim, damage, loss or expense is caused in part by a party indemnified hereunder. The Contractor will not, however, be obligated to indemnify the Board of County Road Commissioners of Allegan County, for any damage or injuries caused by or resulting from the sole negligence of the Board of County Road Commissioners of Allegan County. Such obligation will not be construed to negate, abridge or otherwise reduce other rights or obligations of indemnity which would otherwise exist as a party or person described in this paragraph.

In claims against any person or entity indemnified under this Agreement by an employee of the Contractor, the Contractor's sub-subcontractors, anyone directly or indirectly employed by them or anyone for whose acts they may be liable, the indemnification obligation under this paragraph will not be limited by a limitation on amount or type of damages, compensation or benefits payable by or for the Contractor or the Contractor's subcontractors under workers' or workmen's compensation acts, disability benefit acts or other employee benefit acts.

INSURANCE

A. Contractor's Insurance. Prior to start of the Contractor's work, the Contractor will procure for the Contractor's work and maintain in force until the completion of the work, workers' compensation insurance, employer's liability insurance, comprehensive general liability insurance and all insurance required of the contract under the contract documents.

The Board of County Road Commissioners of Allegan County will be named as an additional insured on each of these policies except for worker's compensation.

The insurance will include contractual liability insurance covering the Contractor's obligations under its agreement of indemnification as set forth herein.

B. Minimum Limits of Liability. The Contractor's comprehensive general and automobile liability insurance as required herein, will be written with limits of liability not less than the following:

a. Comprehensive general liability including completed operations

(1) \$ 500,000 each occurrence

b. Property damage

(1) \$ 500,000 each occurrence

C. Number of Policies. Comprehensive general liability insurance and other liability insurance may be arranged under a single policy for the full limit required or by combination of underlying policies with the balance provided by an excess or umbrella liability policy.

D. Cancellation, Renewal or Modification. The Contractor will maintain in effect all insurance coverage required under this Agreement at the Contractor's sole expense and with insurance companies acceptable to the Board of County Road Commissioners of Allegan County.

All insurance policies will contain a provision that the coverage afforded thereunder will not be cancelled or not renewed nor restrictive modifications added at any time after a certificate of insurance required under agreement has been issued and before the work; as defined herein, has been completed, until at least thirty (30) days prior thereto written notice has been given to the Board of County Road Commissioners of Allegan County unless otherwise specifically required in the Contract Documents.

Certificates of insurance or certified copies of policies acceptable to the Board of County Road Commissioners of Allegan County will be filed with the Board of County Road Commissioners of Allegan County prior to the commencement of the Contractor's work.

In the event that the Contractor fails to obtain or maintain any insurance coverage required under this Agreement, the Board of County Road Commissioners of Allegan County may:

1. Purchase such coverage and charge the expense thereof to the Contractor, and
2. Withhold from any payment due or to become due to the Contractor an amount sufficient to protect the Board of County Road Commissioners of Allegan County from such claims, damages, demands, payments, suits, actions, recoveries, judgments, losses and expenses, including attorney fees, interest and court costs, and
3. Terminate this agreement.

Nothing contained in this Agreement, nor the Board of County Road Commissioners of Allegan County's compliance therewith, will relieve the Contractor from its obligations under the Contract to purchase and maintain required insurance or to indemnify the Board of County Road Commissioners of Allegan County.

PROGRESS CLAUSE

The successful bidder will be required to submit a Progress Schedule, giving an outline of his proposed order of work and to indicate the dates for completion of the work. This outline, when approved by the Road Commission, will become a part of the contract.

PROSECUTION OF THE WORK

The Contractor will begin the work within five (5) days after being notified by the Road Commission of the award of the contract, unless this is inconsistent with the Progress Schedule, in which case the Progress Schedule will govern. He will prosecute the work in the order given in the Progress Schedule, with force and equipment adequate to complete the sections within the time limit therein fixed for completion. In case of failure to proceed with the work as rapidly as is provided in the Progress Schedule, or if it appears at any time that such work is not being prosecuted in such a manner as to insure its completion within time specified, the Road Commission will have the right to require the contractor to furnish and place in operation such additional force and equipment as the Road Commission will deem necessary to bring the work up to the Progress Schedule; and in case of the Contractor's neglect to do so, the Road Commission may place such working force and equipment on the work and charge the Contractor the cost of the labor and such rental and depreciation rates for the plan and equipment as in its judgment is reasonable, and for such time as the plant and equipment are in service.

ESTIMATED QUANTITIES

The quantities listed in the proposal are the estimated quantities. Increases or decreases in quantities will not be considered as a basis for adjustment in unit prices and Articles 109.03 of M.D.O.T. Standard Specifications for Construction will not apply in this regard.

FINAL PAYMENT

Final payment will not be made until the contractor will have filed with the Board of County Road Commissioners the consent of the Surety of the payment of the final estimate and satisfactory evidence by affidavit or otherwise that all his indebtedness by reason of the contract has been fully paid or satisfactorily secured. In case such evidence is not furnished, the Road Commission may retain out of any amount due said contractor sums sufficient to cover all lienable claims unpaid.

AFFIRMATIVE ACTION POLICY (EQUAL EMPLOYMENT OPPORTUNITY EMPLOYER)

The Allegan County Road Commission will require the Contractor to submit an Affirmative Action Policy stating that they are an equal employment opportunity employer and will recruit, hire and promote in all job classifications without regard to race, color, religion, sex or national origin, except where sex is a bona fide occupational qualification. The Affirmative Action Policy will be signed by the Contractor or one of the Company's Authorized Officers.

CONTRACT BONDS

The Successful Bidder will furnish satisfactory performance and lien bonds, each in the amount of not less than one hundred (100) percent of the total contract price. Such bonds will be on forms provided and will meet the regulations of the Allegan County Road Commission and the requirements specified in the laws of Michigan.

Bonds will not be required for contracts of less than \$5,000.00.

M.D.O.T. – PREQUALIFICATION

Contractors bidding on this work must be pre-qualified by the Michigan Department of Transportation to do similar work on State or Federal-aid Secondary projects.

LIQUIDATED DAMAGES

Failure to complete the project on or before the completion date specified will be assessed according to the following schedule:

Original Contract Amount	Liquid Damages Per Calendar Day
\$ 0 to 49,999	75
50,000 to 99,999	150
100,000 to 499,999	450
500,000 to 999,999	900
1,000,000 to 1,999,999	1,300
2,000,000 to 4,999,999	1,550
5,000,000 to 9,999,999	2,650
10,000,000 and above	3,000

The liquidated damages may be waived if the contractor meets the requirements set forth in Section 108.07 of the 2012 Standard Specifications for Construction. Approval of the Engineer is required.

A Contractor's Guide to

STORM WATER POLLUTION PREVENTION



Our Watershed, Our Responsibility

- A watershed is an area of land that catches rain and snow melt and drains into a river, lake, stream, or wetland. There are several major watersheds in Allegan County including the Kalamazoo River Watershed and the Macatawa Watershed.
- As citizens and contractors living and working in Allegan County, it is your duty to ensure that the surface waters of the community are kept clean and healthy.

Where Do Storm Drains Go?

- Storm drains, catch basins, and ditches are directly connected to local waterways.
- This direct connection means that whatever enters the storm drain eventually enters a river, lake, stream or wetland.
- When fertilizer, yard waste, sediment, or other contaminants enter a storm drain, it has adverse effects on local waterways.



Eliminating Illicit Discharges

- An illicit discharge is the discharge of pollutants to storm sewer systems via overland flow or direct dumping into catch basins.

- Illicit discharges are illegal! Reporting them can help eliminate the problem and keep our rivers and streams clean.

Report an illicit discharge to the Pollution Emergency Alerting System (PEAS) at (800) 292-5706 or to the Allegan County Road Commission at (269) 673-2184.

Practicing Healthy Land Care

- Use a fertilizer that is organic slow-release with low or no phosphorus. Phosphorus is the main cause of algae growth in streams, which depletes the oxygen aquatic organisms need to survive.
- Get your soil tested through your county Michigan State University Extension office. This will tell you what fertilizer you should use, if any.
- Don't dump leaves or grass clippings down the drain or blow them into the street! Decaying leaves also deplete the oxygen in streams. They can be used as mulch, or they can be disposed of by curbside pick-up.

Maintaining Your Fleet

- Leaky vehicles and construction machinery can easily cause stream contamination by tracking fluids and other pollutants off site, eventually draining into a catch basin
- You can prevent vehicle fluids from entering local bodies of water by ensuring that your vehicles and equipment are properly maintained and in good working condition.
- Proper disposal of chemicals and other waste is critical to the health of streams and rivers. Solid and liquid waste materials are not meant to be dumped in catch basins. Remember that catch basins are made for storm water only!



- Manage riparian land wisely! Leaving a buffer zone of 20 feet between lawns and streams prevents stream bank erosion, stops pollutants from reaching the stream, and creates a habitat for local wildlife.

Managing Streets and Parking Lots

- Storm water runoff from streets and parking lots is a main cause of pollution because the storm water takes sediment and other solids with it into catch basins.
- The runoff from these impervious surfaces entering streams contains total suspended solids (TSS).
- Suspended solids make water in streams cloudy, which inhibits aquatic plant growth. This in turn affects the health of aquatic organisms that require oxygen from the aquatic plants.
- You can prevent this by keeping roads clean near the construction site and have a designated disposal area for cigarette butts and other small debris that can make its way into a catch basin.



Allegan County Road
Commission
1308 Lincoln Road
Allegan, MI 49010
(269) 673-2184 phone
(269) 673-5922 fax

BID TABULATION - Wednesday, October 14, 2020 - HIGHWAY CONSTRUCTION
 Allegan County Road Commission
 1308 Lincoln Road
 Allegan, Michigan 49010-9762

PROJECT NO. LH 400016– Culvert replacement including grade establishment, sand subbase, aggregate base, HMA paving, gravel shoulders, and restoration on 116th Avenue approximately 3,950 feet east of 56th Street in Clyde Township, Allegan County.

ITEM OF WORK	QUANTITY	UNIT							PRELIMINARY ENGINEER'S ESTIMATE	
			UNIT PRICE BID	AMOUNT	UNIT PRICE BID	AMOUNT	UNIT PRICE BID	AMOUNT	UNIT PRICE BID	AMOUNT
Clearing	1	LS		\$0.00		\$0.00		\$0.00	\$10,000.00	\$10,000.00
Station Grading	1	LS		0.00		0.00		0.00	7,000.00	7,000.00
Subbase, CIP	250	Cyd		0.00		0.00		0.00	10.00	2,500.00
Topsoil Surface, Salv, LM	60	Cyd		0.00		0.00		0.00	10.00	600.00
Geotextile Stabilization	500	Syd		0.00		0.00		0.00	3.00	1,500.00
Aggregate, 6A	50	Ton		0.00		0.00		0.00	30.00	1,500.00
Subgrade Undercutting, Type II	200	Cyd		0.00		0.00		0.00	10.00	2,000.00
Precast Concrete Box Culvert, 12' x 7'	48	Ft		0.00		0.00		0.00	1,750.00	84,000.00
Aggregate Base, 6 inch	425	Syd		0.00		0.00		0.00	8.00	3,400.00
Shoulder, CI II	35	Ton		0.00		0.00		0.00	30.00	1,050.00
HMA, LVSP	65	Ton		0.00		0.00		0.00	130.00	8,450.00
Restoration	1	LS		0.00		0.00		0.00	3,000.00	3,000.00
Extended Restoration	1	LS		0.00		0.00		0.00	1,000.00	1,000.00
Seeding, Mixture CR	50	Lb		0.00		0.00		0.00	5.00	250.00
Sign, Type B, Temp, Modified	126	Sft		0.00		0.00		0.00	10.00	1,260.00
Plastic Drum, High Intensity, Ltd, Modified	20	Ea		0.00		0.00		0.00	25.00	500.00
Barricade Type III, High Intensity, Dbl Sided, Ltd, Modified	6	Ea		0.00		0.00		0.00	130.00	780.00
Riprap, Plain	60	Syd		0.00		0.00		0.00	50.00	3,000.00
Mulch Blanket, High Velocity	300	Syd		0.00		0.00		0.00	2.50	750.00
Erosion Control, Silt Fence	400	Ft		0.00		0.00		0.00	2.50	1,000.00
Project Cleanup	1	LS		0.00		0.00		0.00	2,000.00	2,000.00
			TOTAL BID	\$0.00	TOTAL BID	\$0.00	TOTAL BID	\$0.00	TOTAL BID	\$135,540.00



NOTICE OF AUTHORIZATION

Permit Number: WRP025198 v. 1

Date Issued: September 23, 2020

Site Name: 03 - 116th Avenue Culvert Replacement - Clyde Township

Expiration Date: September 23, 2025

The Michigan Department of Environment, Great Lakes, and Energy (EGLE), Water Resources Division, P.O. Box 30458, Lansing, Michigan 48909-7958, under provisions of the Natural Resources and Environmental Protection Act, 1994 PA 451, as amended: specifically:

- Part 31, Floodplain Regulatory Authority of the Water Resources Protection.
- Part 301, Inland Lakes and Streams.
- Part 303, Wetlands Protection.
- Part 315, Dam Safety.
- Part 323, Shorelands Protection and Management.
- Part 325, Great Lakes Submerged Lands.
- Part 353, Sand Dunes Protection and Management.

Authorized activity:

Remove the existing structure at the 116th Avenue crossing North State Road and Spaulding Drain. Install a single, 48 foot long by 12 foot span by 7 foot rise precast concrete box culvert with a 1-foot recess. Install 11-cubic yards of riprap for scour protection. Project will impact 0.02 acres of adjacent wetland. No mitigation is required.

To be conducted at property located in Allegan County, Waterbody: North State Road and Spaulding Drain Section 28, Town 02N, Range 15W, Clyde Township

Permittee:
Ryan Brown
Allegan County Road Commission
1308 Lincoln Road
Allegan, Michigan 49010

Issued By:

Holly Vickers
Transportation Review Unit
Water Resources Division
616-295-2787

*This notice must be displayed at the site of work.
Laminating this notice or utilizing sheet protectors is recommended.*
Please refer to the above permit number with any questions or concerns.

EGLE-WRD
WRP025198 v1.0
Approved
Issued On:09/23/2020
Expires On:09/23/2025



**MICHIGAN DEPARTMENT OF ENVIRONMENT, GREAT LAKES, AND ENERGY
WATER RESOURCES DIVISION PERMIT**

Issued To:

**Allegan County Road Commission
1308 Lincoln Road
Allegan, Michigan 49010**

Permit No: WRP025198 v.1
Submission No.: HP1-JW9Y-70AGB
Site Name: 03 - 116th Avenue Culvert Replacement - Clyde Township
Issued: September 23, 2020
Revised:
Expires: September 23, 2025

This permit is being issued by the Michigan Department of Environment, Great Lakes, and Energy (EGLE), Water Resources Division, under the provisions of the Natural Resources and Environmental Protection Act, 1994 PA 451, as amended (NREPA); specifically:

- | | |
|---|---|
| <input checked="" type="checkbox"/> Part 301, Inland Lakes and Streams | <input type="checkbox"/> Part 323, Shorelands Protection and Management |
| <input checked="" type="checkbox"/> Part 303, Wetlands Protection | <input type="checkbox"/> Part 325, Great Lakes Submerged Lands |
| <input type="checkbox"/> Part 315, Dam Safety | <input type="checkbox"/> Part 353, Sand Dunes Protection and Management |
| <input checked="" type="checkbox"/> Part 31, Water Resources Protection (Floodplain Regulatory Authority) | |

Permission is hereby granted, based on permittee assurance of adherence to State of Michigan requirements and permit conditions, to:

Authorized Activity:

Remove the existing structure at the 116th Avenue crossing North State Road and Spaulding Drain. Install a single, 48 foot long by 12 foot span by 7 foot rise precast concrete box culvert with a 1-foot recess. Install 11-cubic yards of riprap for scour protection. Project will impact 0.02 acres of adjacent wetland. No mitigation is required.

Waterbody Affected: North State Road and Spaulding Drain
Property Location: Allegan County, Clyde Township, Town/Range/Section 02N15W28

Authority granted by this permit is subject to the following limitations:

- A. Initiation of any work on the permitted project confirms the permittee's acceptance and agreement to comply with all terms and conditions of this permit.
- B. The permittee, in exercising the authority granted by this permit, shall not cause unlawful pollution as defined by Part 31 of the NREPA.
- C. This permit shall be kept at the site of the work and available for inspection at all times during the duration of the project or until its date of expiration.
- D. All work shall be completed in accordance with the approved plans and specifications submitted with the application and/or plans and specifications attached to this permit.

**EGLE-WRD
WRP025198 v1.0
Approved
Issued On:09/23/2020
Expires On:09/23/2025**

- E. No attempt shall be made by the permittee to forbid the full and free use by the public of public waters at or adjacent to the structure or work approved.
- F. It is made a requirement of this permit that the permittee give notice to public utilities in accordance with 2013 PA 174 (Act 174) and comply with each of the requirements of Act 174.
- G. This permit does not convey property rights in either real estate or material, nor does it authorize any injury to private property or invasion of public or private rights, nor does it waive the necessity of seeking federal assent, all local permits, or complying with other state statutes.
- H. This permit does not prejudice or limit the right of a riparian owner or other person to institute proceedings in any circuit court of this state when necessary to protect his rights.
- I. Permittee shall notify EGLE within one week after the completion of the activity authorized by this permit by completing and forwarding the attached preaddressed postcard to the office addressed thereon.
- J. This permit shall not be assigned or transferred without the written approval of EGLE.
- K. Failure to comply with conditions of this permit may subject the permittee to revocation of permit and criminal and/or civil action as cited by the specific state act, federal act, and/or rule under which this permit is granted.
- L. All dredged or excavated materials shall be disposed of in an upland site (outside of floodplains, unless exempt under Part 31 of the NREPA, and wetlands).
- M. In issuing this permit, EGLE has relied on the information and data that the permittee has provided in connection with the submitted application for permit. If, subsequent to the issuance of a permit, such information and data prove to be false, incomplete, or inaccurate, EGLE may modify, revoke, or suspend the permit, in whole or in part, in accordance with the new information.
- N. The permittee shall indemnify and hold harmless the State of Michigan and its departments, agencies, officials, employees, agents, and representatives for any and all claims or causes of action arising from acts or omissions of the permittee, or employees, agents, or representative of the permittee, undertaken in connection with this permit. The permittee's obligation to indemnify the State of Michigan applies only if the state: (1) provides the permittee or its designated representative written notice of the claim or cause of action within 30 days after it is received by the state, and (2) consents to the permittee's participation in the proceeding on the claim or cause of action. It does not apply to contested case proceedings under the Administrative Procedures Act, 1969 PA 306, as amended, challenging the permit. This permit shall not be construed as an indemnity by the State of Michigan for the benefit of the permittee or any other person.
- O. Noncompliance with these terms and conditions and/or the initiation of other regulated activities not specifically authorized shall be cause for the modification, suspension, or revocation of this permit, in whole or in part. Further, EGLE may initiate criminal and/or civil proceedings as may be deemed necessary to correct project deficiencies, protect natural resource values, and secure compliance with statutes.
- P. If any change or deviation from the permitted activity becomes necessary, the permittee shall request, in writing, a revision of the permitted activity from EGLE. Such revision request shall include complete documentation supporting the modification and revised plans detailing the proposed modification. Proposed modifications must be approved, in writing, by EGLE prior to being implemented.
- Q. This permit may be transferred to another person upon written approval of EGLE. The permittee must submit a written request to EGLE to transfer the permit to the new owner. The new owner must also submit a written request to EGLE to accept transfer. The new owner must agree, in writing, to accept all conditions of the permit. A single letter signed by both parties that includes all the above information may be provided to EGLE. EGLE will review the request and, if approved, will provide written notification to the new owner.
- R. Prior to initiating permitted construction, the permittee is required to provide a copy of the permit to the contractor(s) for review. The property owner, contractor(s), and any agent involved in exercising the permit are held responsible to ensure that the project is constructed in accordance with all drawings and specifications. The contractor is required to provide a copy of the permit to all subcontractors doing work authorized by the permit.
- S. Construction must be undertaken and completed during the dry period of the wetland. If the area does not dry out, construction shall be done on equipment mats to prevent compaction of the soil.

- T. Authority granted by this permit does not waive permit requirements under Part 91, Soil Erosion and Sedimentation Control, of the NREPA, or the need to acquire applicable permits from the County Enforcing Agent (CEA).
- U. Authority granted by this permit does not waive permit requirements under the authority of Part 305, Natural Rivers, of the NREPA. A Natural Rivers Zoning Permit may be required for construction, land alteration, streambank stabilization, or vegetation removal along or near a natural river.
- V. The permittee is cautioned that grade changes resulting in increased runoff onto adjacent property is subject to civil damage litigation.
- W. Unless specifically stated in this permit, construction pads, haul roads, temporary structures, or other structural appurtenances to be placed in a wetland or on bottomland of the water body are not authorized and shall not be constructed unless authorized by a separate permit or permit revision granted in accordance with the applicable law.
- X. For projects with potential impacts to fish spawning or migration, no work shall occur within fish spawning or migration timelines (i.e., windows) unless otherwise approved in writing by the Michigan Department of Natural Resources (MDNR), Fisheries Division.
- Y. Work to be done under authority of this permit is further subject to the following special instructions and specifications:
1. All work shall be completed in accordance with plans attached; kept on file at EGLE, WRD, Transportation Review Unit.
 2. Authority granted by this permit does not waive compliance requirements under Part 91, Soil Erosion and Sedimentation Control, of the NREPA. Any discharge of sediment into waters of the state and/or off the road right-of-way is a violation of this permit, Part 91, and Part 31, Water Resources Protection, of the NREPA. A violation of these parts subjects the permittee to potential fines and penalties.
 3. This permit does not authorize or sanction work that has been completed in violation of applicable federal, state, or local statutes.
 4. The permittee is responsible for acquiring all necessary easements or rights-of-way before commencing any work authorized by this permit. All construction operations relating to or part of this project shall be confined to the existing right-of-way limits or other acquired easements.
 5. Temporary soil erosion and sedimentation control measures shall be installed before or upon commencement of the earth change and shall be maintained daily. Temporary soil erosion and sedimentation control measures shall be maintained until permanent soil erosion and sedimentation control measures are in place and the area is stabilized. Permanent soil erosion and sedimentation control measures for all slopes, channels, ditches, or any disturbed area shall be installed within five (5) calendar days after final grading or the final earth change has been completed.
 6. All raw areas in uplands resulting from the permitted construction activity shall be effectively stabilized with sod and/or seed and mulch (or other technology specified by this permit or project plans) in a sufficient quantity and manner to prevent erosion and any potential siltation to surface waters or wetlands. Temporary stabilization measures shall be installed before or upon commencement of the permitted activity and shall be maintained until permanent measures are in place. Permanent measures shall be in place within five (5) days of achieving final grade.
 7. All raw earth within 100 feet of a lake, stream, or wetland that is not brought to final stabilization by the end of the active growing season shall be temporarily stabilized with mulch blankets in accordance with the following dates: September 20th for the Upper Peninsula, October 1st for the Lower Peninsula north of US-10, and October 10th for the Lower Peninsula south of US-10.

8. This permit placard shall be kept posted at the work site, in a prominent location at all times for the duration of the project, or until permit expiration.
9. This permit is being issued for the maximum time allowed and no extensions of this permit will be granted. Initiation of the construction work authorized by this permit indicates the permittee's acceptance of this condition. The permit, when signed by EGLE, will be for a five-year period beginning at the date of issuance. If the project is not completed by the expiration date, a new permit must be sought.
10. All dredge/excavated spoils including organic and inorganic soils, vegetation, and other material removed shall be placed on upland (non-wetland, non-floodplain or non-bottomland), prepared for stabilization, revegetated and reseeded with native Michigan species appropriate to the site, and mulched in such a manner so as to prevent and ensure against erosion of any material into any waterbody, wetland, or floodplain.
11. Unless specifically stated under the "Permitted Activity" of this permit, construction pads, haul roads, temporary structures, or other structural appurtenances to be placed in a wetland or on bottomland of the waterbody are not authorized and shall not be constructed unless authorized by a separate permit or permit revision granted in accordance with the applicable law.
12. During removal or repair of the existing structure, every precaution shall be taken to prevent debris from entering any watercourse. Any debris reaching the watercourse during the removal and/or reconstruction of the structure shall be immediately retrieved from the water. All material shall be disposed of in an acceptable manner consistent with local, state, and federal regulations.
13. Prior to the removal of the existing structures, cofferdams of steel sheet piling, gravel bags, clean stone, coarse aggregate, concrete or other acceptable barriers shall be installed to isolate all construction activity from the water. The barriers shall be maintained in good working order throughout the duration of the project. Upon project completion, the accumulated materials shall be removed and disposed of at an upland site.
14. All cofferdam and temporary steel sheet pile shall then be removed in its entirety, unless specifically shown to be left in place on the accepted plans. Cofferdam and sheet pile that is left in place shall be cut off at the elevation shown on the plans and shall be a minimum of one foot below the stream bottom.
15. The existing structure shall be kept open to pass the stream flow during removal of the existing road fill.
16. The placement of the new culvert and the initial placement of fill in the stream shall be done immediately after removal of the existing culvert. The placement shall be conducted in such a manner that all flow is immediately passed through the new culverts, allowing the major placement of fill to be done in the dry or in still water where erosion and sedimentation will be minimized. The fill material used in this initial placement shall be washed gravel, coarse aggregate, or rock and shall be placed at both ends of the culvert to a level above normal water level before backfill material is placed.
17. The culvert shall be installed to align with the center line of the existing stream at both the inlet and outlet ends, and must be **recessed into the stream bed** to provide a natural channel substrate throughout the structure, as shown on the approved plans.
18. Road fill side slopes shall not be steeper than 1-on-2 (1 vertical to 2 horizontal) except where headwalls of reinforced concrete, mortar masonry, dry masonry, or other acceptable methods are used.

19. Road fill side slopes terminating in the stream and any raw streambanks resulting from the construction shall be stabilized with temporary measures in accordance with appropriate Best Management Practices based on site conditions, and if necessary, may be riprapped extending above the ordinary high water mark, before or upon commencement of the permitted activity. Temporary stabilization measures shall be maintained until permanent measures are in place.
20. All other road fill slopes, ditches, and other raw areas draining directly to the stream may be protected with riprap, sod and/or seed and mulch as may be necessary to provide effective erosion protection. The placement of riprap shall be limited to the minimum necessary to ensure proper stabilization of the side slopes and fill in the immediate vicinity of the structure.
21. All riprap shall be properly sized and graded based on wave action and velocity and shall consist of natural field stone or rock (free of paint, soil or other fines, asphalt, soluble chemicals, or organic material). Broken concrete is not allowed.
22. If the project, or any portion of the project, is stopped and lies incomplete for any length of time other than that encountered in a normal work week, every precaution shall be taken to protect the incomplete work from erosion, including the placement of temporary gravel bag riprap, temporary seed and mulch, or other acceptable temporary protection.
23. No work shall be done in the stream during periods of above-normal flows except as necessary to prevent erosion.
24. To avoid disturbance of Northern long-eared bat, which is federally listed as a threatened species, or Indiana bat, which is federally listed as an endangered species, any tree larger than three inches in diameter shall not be cut between April 1 and September 30 of any year.
25. This project occurs within an area that is considered to be occupied by the federally threatened eastern massasauga rattlesnake (EMR). The following BMPs are necessary to avoid potential take of EMR.
 - Use wildlife-safe materials for erosion control and site restoration. Eliminate the use of erosion control products containing plastic mesh netting or other similar materials that could entangle EMR.
 - To increase human safety and awareness of EMR, those implementing the project should first watch MDNR's "60-Second Snakes: The Eastern Massasauga Rattlesnake" video (available at https://youtu.be/~PFnXe_e02w), or review the EMR factsheet (available at <https://www.fws.gov/midwest/endangered/reptiles/eama/pdf/EMRfactsheetSep2016.pdf>), or call (517) 351-2555.
 - During project implementation, require reporting of any federally listed species, including EMR, to the Service within 24 hours.
 - Exclusionary fencing should be used as a barrier around the project site that occurs within or adjacent to EMR habitat. Once the fence is installed the construction area should be cleared by qualified individual who has demonstrated experience in identification of EMR or otherwise approved by the Service. The exclusionary fencing should be walked weekly to ensure the integrity of the barrier. Once construction activities are complete, the exclusionary fence should be removed from the sit
 - The project site should be revegetated with appropriate native or natural wetland plants to maintain the quality of the existing wetland and prevent the establishment of invasive species.
26. **No work or dredging within the water authorized by this permit is allowed from March 1 through June 30 due to critical spawning, migration, and/or recreational use periods.**

27. Prior to the start of construction, all adjacent non-work wetland areas shall be protected by properly trenched sedimentation barrier to prevent sediment from entering the wetland. Orange construction fencing shall be installed as needed to prohibit construction personnel and equipment from entering or performing work in these areas. Fence shall be maintained daily throughout the construction process. Upon project completion, the accumulated materials shall be removed and disposed of at an upland site, the sedimentation barrier shall then be removed in its entirety and the area restored to its original configuration and cover.
28. Stormwater shall not directly outlet to the stream.



Issued By:

Holly Vickers
Transportation Review Unit
Water Resources Division
616-295-2787

cc: Clyde Township Clerk
Allegan County Drain Commissioner
Allegan CEA
Janelle Hohm, EGLE
Jason Combs, EGLE
Brian Gunderman, MDNR, Fisheries

ALLEGAN COUNTY ROAD COMMISSION

116TH AVENUE CULVERT REPLACEMENT PROJECT

3,950' EAST OF 56TH STREET

CLYDE TOWNSHIP

**Board of County Road Commissioners
Of Allegan County**
1308 LINCOLN ROAD
ALLEGAN, MICHIGAN 49010-9762
www.alleganroads.org FAX (269) 673-5922
TELEPHONE (269) 673-2184

REVISIONS	
1	
2	
3	
4	
5	
6	
7	

116TH AVENUE CULVERT REPLACEMENT PROJECT
CLYDE TOWNSHIP - 3950' EAST OF 56TH STREET

COVER SHEET

DRAWN BY: RPB
REVIEWED BY:
DATE: JULY, 2020
SCALE: NONE

EGLE 1
Approved
Issued On: 09/23/2020
Expires On: 09/23/2025

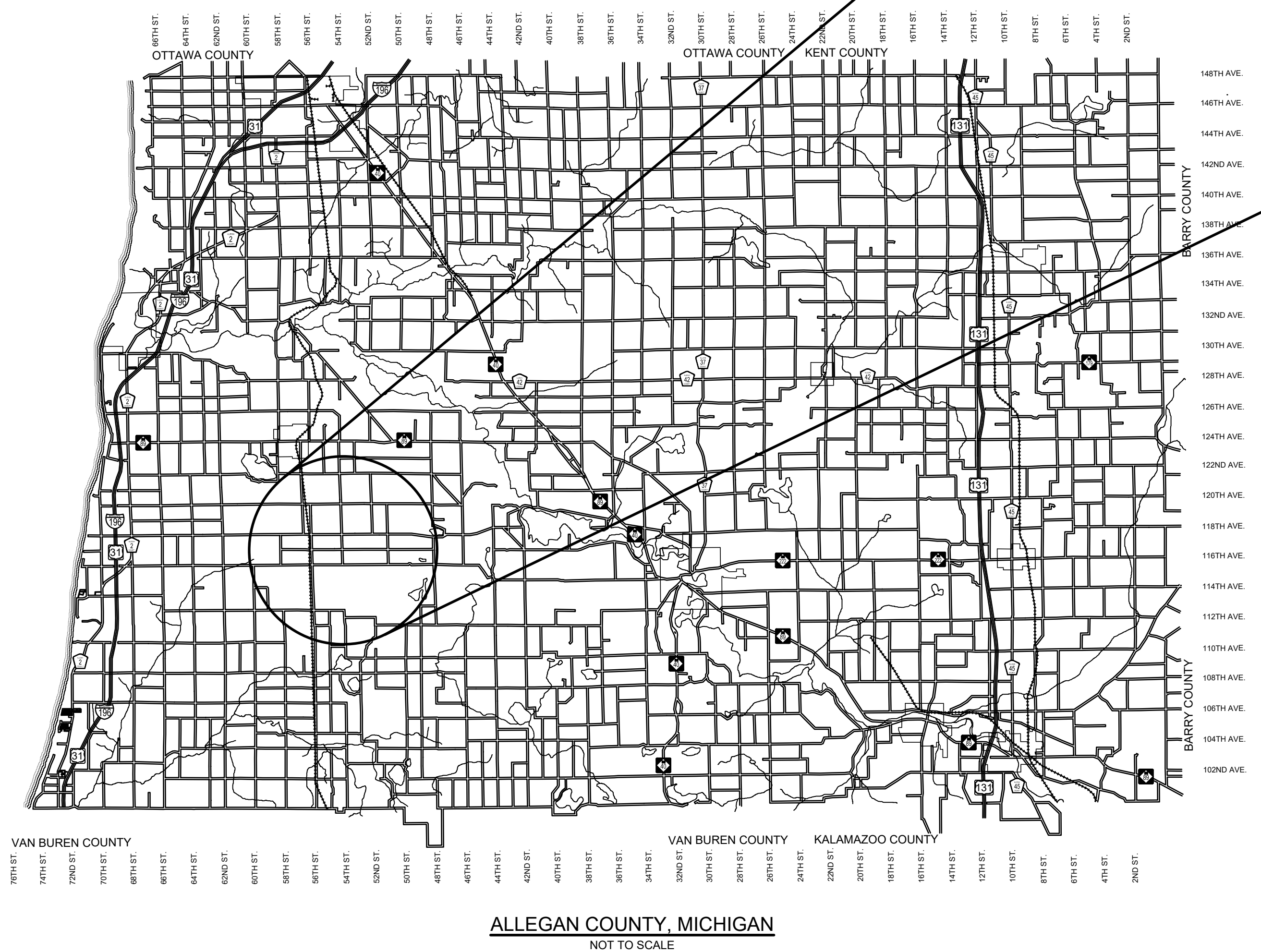
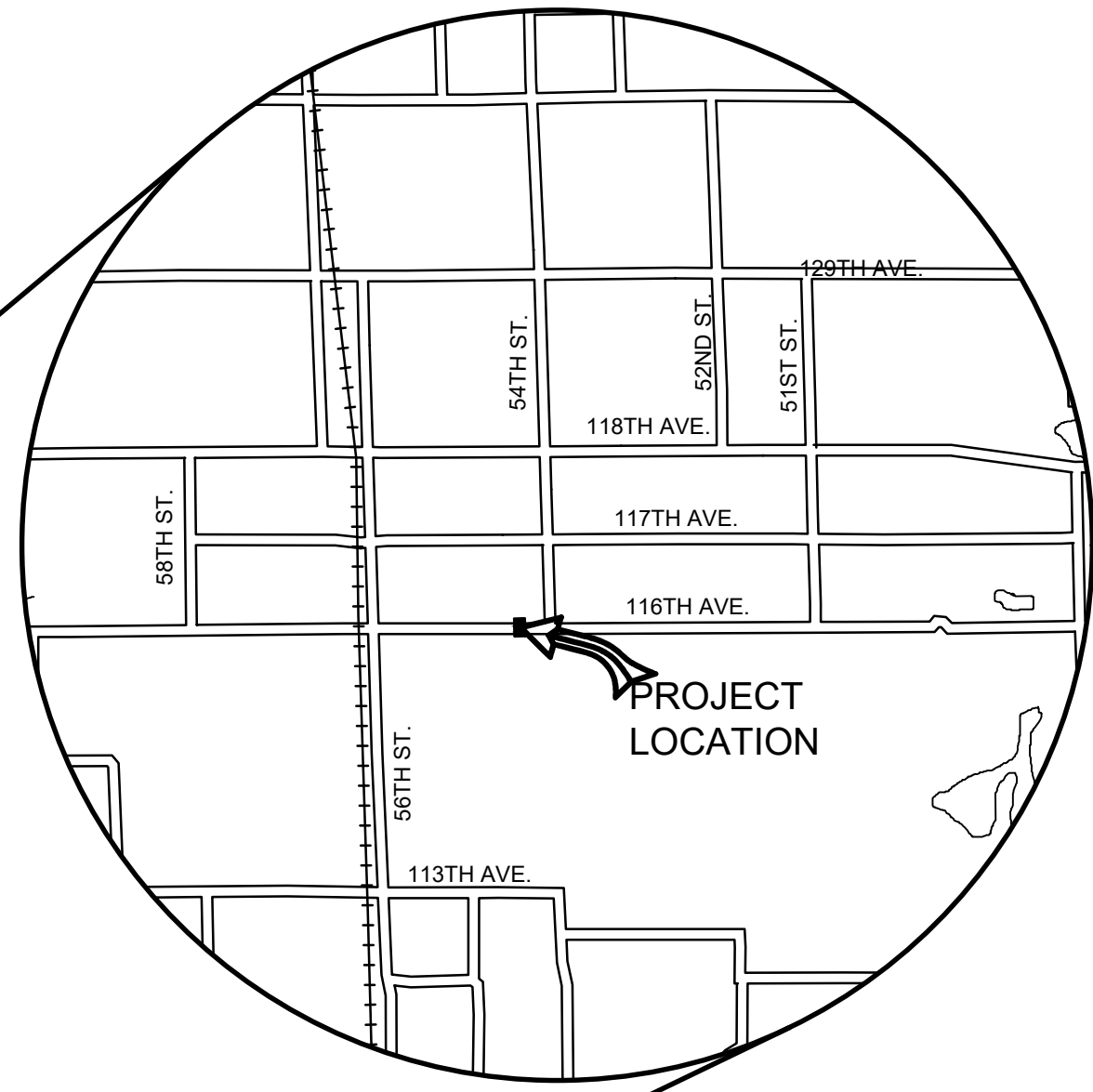

INDEX OF PLANS
1 - COVER SHEET
2 - ROAD PLAN AND PROFILE
3 - STREAM PLAN AND PROFILE

PREPARED UNDER THE SUPERVISION OF:

RYAN P. BROWN
REGISTERED PROFESSIONAL ENGINEER No. 65933

04-021-045-10
 LAWRENCE BILLINGS
 5445 116TH AVENUE
 FENNVILLE, MI 49408

04-021-046-00
 DEPARTMENT OF CONSERVATION

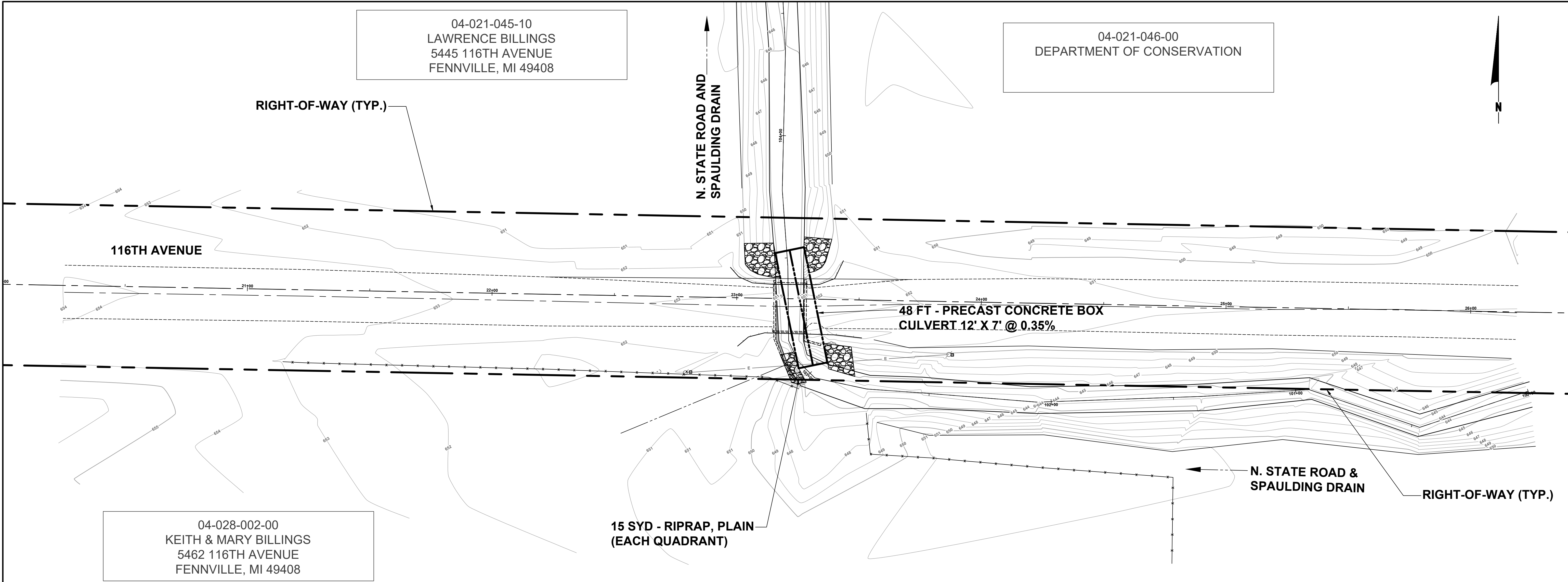

04-028-002-00
 KEITH & MARY BILLINGS
 5462 116TH AVENUE
 FENNVILLE, MI 49408

**Board of County Road Commissioners
 Of Allegan County**
 1308 LINCOLN ROAD
 ALLEGAN, MICHIGAN 49010-9762
 TELEPHONE (269) 673-2184 www.alleganroads.org FAX (269) 673-5922

REVISIONS	
1	
2	
3	
4	
5	
6	
7	

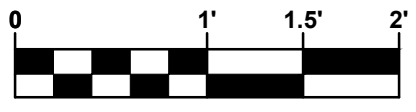
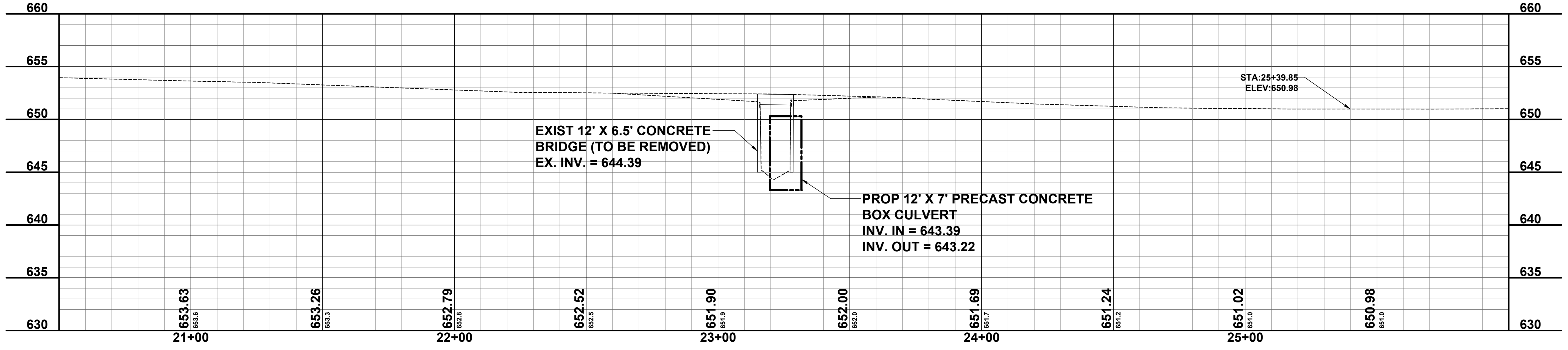

116TH AVENUE CULVERT REPLACEMENT
 CLYDE TOWNSHIP - 3950' EAST OF 56TH STREET

ROAD PLAN & PROFILE

DRAWN BY: RPB
 REVIEWED BY:
 DATE: JULY, 2020
 SCALE: 1" = 20'H, 5'V

LH 400016 | 2

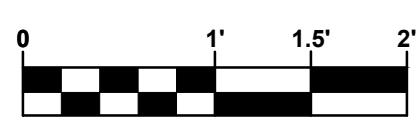
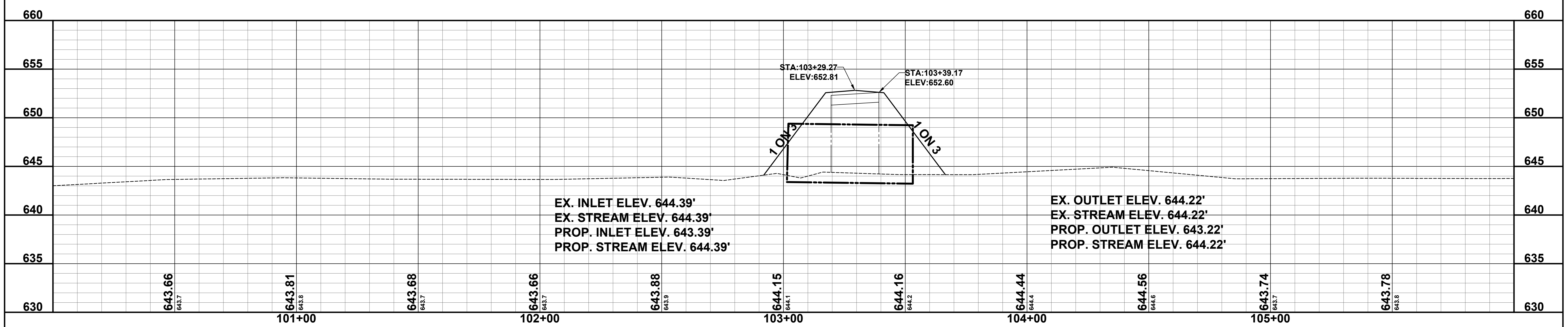
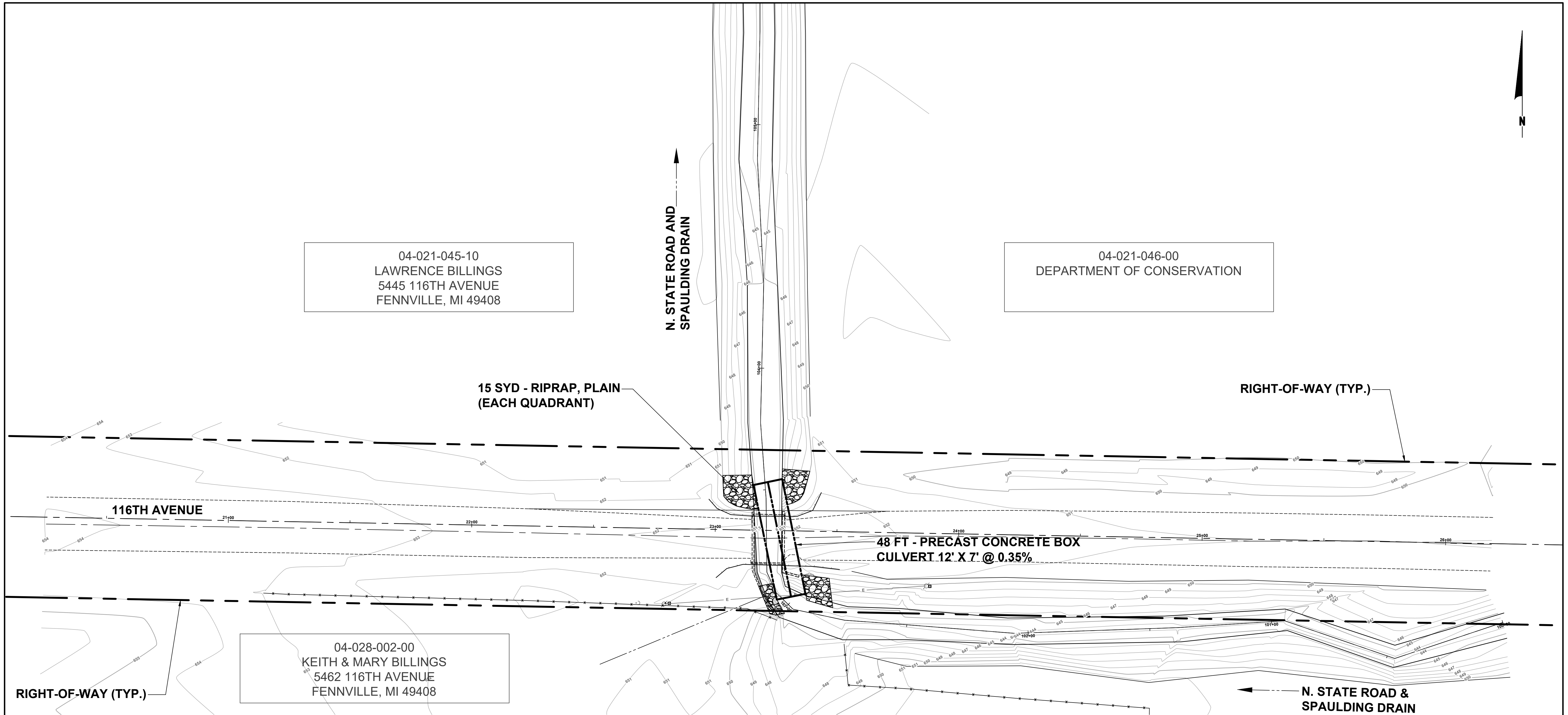

**Board of County Road Commissioners
Of Allegan County**
1308 LINCOLN ROAD
ALLEGAN, MICHIGAN 49010-9762
TELEPHONE (269) 673-2184 www.alleganroads.org FAX (269) 673-5922

REVISIONS
1
2
3
4
5
6
7

116TH AVENUE CULVERT REPLACEMENT
CLYDE TOWNSHIP - 3950' EAST OF 56TH STREET

STREAM PLAN & PROFILE

DRAWN BY: RPB
REVIEWED BY:
DATE: JULY, 2020
SCALE: 1" = 20'H, 5'V

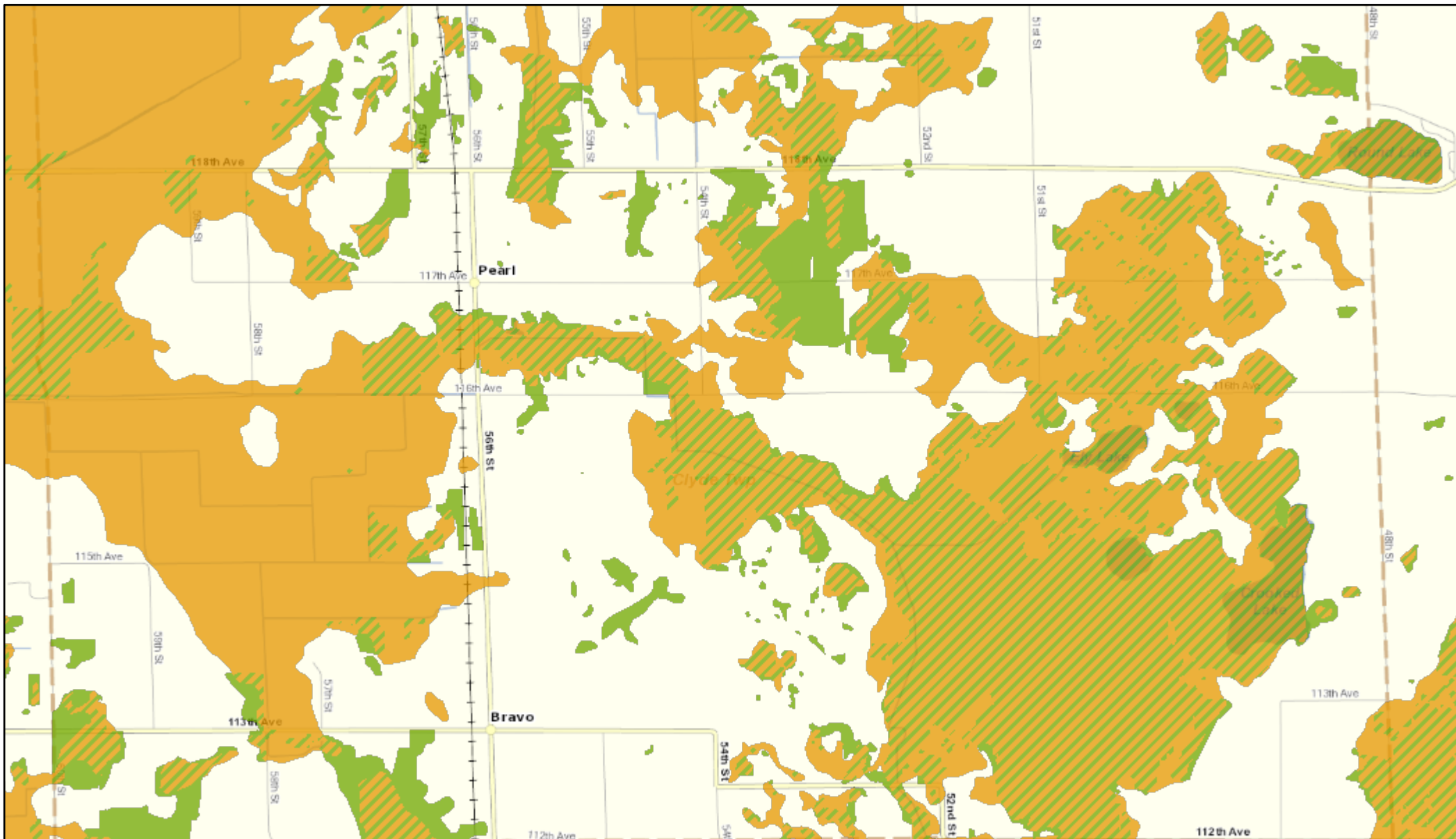

LH 400016 3

Wetlands Map Viewer



July 28, 2020

Part 303 Final Wetlands Inventory

-  Wetlands as identified on NWI and MIRIS maps
-  Soil areas which include wetland soils
-  Wetlands as identified on NWI and MIRIS maps and soil areas which include wetland soils

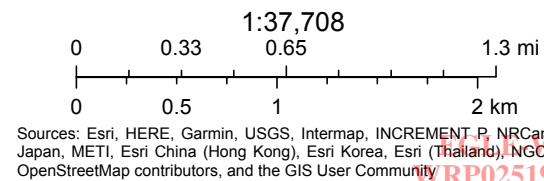

Disclaimer: This map is not intended to be used to determine the specific

Approved
Expires On: 09/23/2025