

CONTRACTOR: \_\_\_\_\_



**PROPOSAL AND SPECIFICATIONS**  
**FOR**  
**SNOW REMOVAL ON DESIGNATED ROADS**  
**IN**  
**OTSEGO AND GUN PLAIN AREAS**

**CONTRACT YEARS 2019-2022**

**NOVEMBER 13, 2019**

BOARD OF COUNTY ROAD COMMISSIONERS  
OF ALLEGAN COUNTY, MICHIGAN

1308 Lincoln Rd., Allegan, MI 49010

ALLEGAN COUNTY ROAD COMMISSION

ADVERTISEMENT FOR BIDS

SNOW REMOVAL

Sealed bids will be received by the Allegan County Road Commission at their office at 1308 Lincoln Road (M-89), Allegan, Michigan, until 11:00 a.m., E.S.T., Wednesday, November 13, 2019, and at such time will be publicly opened and read aloud for the following:

CONTRACT SNOW REMOVAL & ICE CONTROL ON DESIGNATED ROADS IN OTSEGO AND GUN PLAIN AREAS.

Complete specifications and bid forms are available at the Road Commission office and on the website at <http://www.alleganroads.org/2019-projects--bids.html> .

All bids must be submitted on forms furnished by the Road Commission and sealed in envelopes with the name and address of the bidder, and the item bid upon clearly marked thereon.

The Commission reserves the right to reject any or all bids, to waive minor technicalities, and to accept the bid that is deemed to be in the best interest of the County of Allegan.

BOARD OF COUNTY ROAD COMMISSIONERS  
OF ALLEGAN COUNTY, MICHIGAN

John Kleinheksel, Chairman  
James Rybicki, Vice-Chairman  
Larry Brown, Member

BID and AWARD

Date \_\_\_\_\_

Board of County Road Commissioners  
of Allegan County  
1308 Lincoln Road  
Allegan, MI 49010

Gentlemen:

The undersigned has examined the plans, specifications, and location of the work described herein and is fully informed as to the nature of the work and the conditions relating to its performance and understands that the quantities shown in the estimate are approximate only and are subject to either increase or decrease; and hereby proposes to furnish all necessary machinery, tools, apparatus and other means of doing the work, do all the work, furnish all the materials except as otherwise specified herein, and, for the unit prices named in the accompanying unit price schedule, to complete work in strict accordance with the plans and specifications therefore.

The undersigned further proposes to do such extra work as may be ordered by you, prices for which are not included in the itemized bid, compensation therefore to be made on the basis agreed upon before such extra work is begun.

THE CONTRACT

The Contract Documents consist of the bid documents, this Agreement, Conditions of the Contract (General, Supplementary, Special and other Conditions), Drawings, Specifications, Addenda issued prior to execution of this Agreement, other documents listed in this Agreement and Modifications issued after execution of this Agreement; these form the Contract, and are as fully a part of the Contract as if attached to this Agreement or repeated herein. The Contract represents the entire and integrated agreement between the parties hereto and supersedes prior negotiations, representations or agreements, either written or oral. If anything in the other Contract Documents is inconsistent with this Agreement, this Agreement shall govern.

I hereby state that all of the information I have provided is true, accurate and complete. I hereby state that I have the authority to submit this bid which will become a binding contract if accepted by the Board of County Road Commissioners of Allegan County. I hereby state that I have not communicated with nor otherwise colluded with any other bidder, nor have I made any agreement with nor offered or accepted anything of value from an official or employee of the Board of County Road Commissioners of Allegan County that would tend to destroy or hinder free competition.

In case the bidder is a co-partnership, each member must sign this proposal. In case the bidder is a Corporation, this proposal must be executed by its duly authorized official in accordance with its articles of incorporation and a certified copy of such articles must be attached hereto.

I hereby state that I have read, understand and agree to be bound by all the terms of this bid document.

SIGNED: \_\_\_\_\_ NAME: \_\_\_\_\_  
(Type or Print)

TITLE: \_\_\_\_\_ DATE: \_\_\_\_\_

FIRM NAME: \_\_\_\_\_ PHONE: \_\_\_\_\_

ADDRESS: \_\_\_\_\_  
(Street Address) (City) (State) (Zip)

\*\*\*\*\*

**FOR COUNTY USE ONLY - DO NOT WRITE BELOW**

ACCEPTED BY: BOARD OF COUNTY ROAD COMMISSIONERS  
OF THE COUNTY OF ALLEGAN, MICHIGAN

\_\_\_\_\_  
Chairman

\_\_\_\_\_  
Vice-Chairman

\_\_\_\_\_  
Commissioner

\_\_\_\_\_  
Date

## GENERAL SPECIFICATIONS

### SPECIAL CONDITIONS

Special requirements, regulations or directions applying to a particular project may be made a part of these specifications.

### THE WORK

The work consists of the completed services, required by the Contract Documents and includes all materials and labor incorporated or to be incorporated therein.

### RESPONSIBILITIES OF CONTRACTOR

A. Responsibility for and Supervision of Work. Unless otherwise stated herein, Contractor shall be solely responsible for all work under this Contract, including the methods, techniques, sequences, procedures, and means, and for coordination of all work. Contractor shall supervise and direct the work to the best of Contractor's ability, and give it all attention necessary for such proper supervision and direction.

B. Discipline and Employment. Contractor shall maintain at all times strict discipline among Contractor's employees, and contractor agrees not to employ for work on the project any person unfit or without sufficient skill to perform the job for which he or she was employed.

C. Furnishing of Labor, Materials, etc. Unless otherwise stated herein, Contractor shall provide and pay for all labor, materials, and equipment, including tools, construction equipment, and machinery, utilities, including water, transportation, and all other facilities and services necessary for the proper completion of work on the project in accordance with the Contract Documents. One exception being sand-salt mixture shall be supplied by the road commission.

D. Payment of Taxes; Procurement of Licenses and Permits. Contractor shall pay all taxes required by law in connection with work on the project in accordance with this agreement including sales, use, and similar taxes, and shall secure all licenses and permits necessary for proper completion of the work, paying the fees for such licenses and permits.

E. Compliance with Laws and Regulations. Contractor shall comply with all laws and ordinances, and the rules, regulations or orders of all public authorities relating to the performance of the work under and pursuant to this Agreement including, but not limited to, the Occupational Safety and Health Act of 1970, the Michigan Occupational Safety and Health Act, and the rules and regulations of the Michigan Construction Safety Commission.

F. Responsibility for Negligence of Employees and Subcontractors. Contractor assumes full responsibility for acts, negligence or omissions of all of Contractor's employees on the project, for those of Contractor's subcontractors and their employees, and for those of all other persons doing work under a contract with Contractor.

G. Responsibility for Safety. Unless otherwise stated herein, at Contractor's expense, Contractor shall take all necessary precautions (including, without limitation, the furnishing of traffic control, barricades, traffic control devices, flaggers, warning lights, signs, warning signs, safety channels, channelization devices, guards, fences, walks, flags, cables and lights) for the safety of, and the prevention of injury, loss and damage to, persons and property (including, without limitation, in the term persons, members of the public, employees and agents of the Board of County Road Commissioners of Allegan County, Contractor's employees, Contractor's subcontractors and their respective employees, other contractors, their subcontractors and respective employees) on, about or adjacent to the location where the work is being performed, and shall comply with all applicable provisions of safety rules, ordinances, codes, regulations, and orders of duly-constituted public authorities including, but not limited to, the Michigan Manual of Uniform Traffic Control Devices.

H. Responsibility of Subcontractors. The Contractor shall require any subcontractor hired by the Contractor for the purpose of performing any of the work described by the Contract documents to be bound by all of the terms and conditions of the Contract documents and to perform the work in accordance with the Contract documents. Each and every condition of the Contract documents, including without limitation, the RESPONSIBILITIES OF THE CONTRACTOR, shall be made a condition of each subcontract entered into by the Contractor in conjunction with the performance of the work.

#### INDEMNIFICATION

To the fullest extent permitted by law, the Contractor shall indemnify, defend, and hold harmless The Board of County Road Commissioners of Allegan County, its officers, employees, representatives and agents from and against any and all claims, damages, demands, payments, suits, actions, recoveries, judgments, losses and expenses, including attorney fees, interest, and court costs, which are made, brought or recovered against the Board of County Road Commissioners of Allegan County, arising out of or resulting from performance of the Contractor's work under this Contract, provided that such claims, damages, losses, demands, payments, suits, actions, recoveries, judgments and/or expenses are attributable to bodily injury, sickness, disease or death, or to injury to or destruction of tangible property (other than the work itself) including loss of use resulting therefrom, but only if caused in whole or in part, by the act, omission, fault, negligence or breach of the conditions of this Contract by negligent acts or omissions of the Contractor, the Contractor's sub-subcontractors, anyone directly or indirectly employed by them or anyone for whose acts they may be liable, regardless of whether or not such claim, damage, loss or expense is caused in part by a party indemnified hereunder. The Contractor shall not, however, be obligated to indemnify the Board of County Road Commissioners of Allegan County, for any damage or injuries caused by or resulting from the sole negligence of the Board of County Road Commissioners of Allegan County. Such obligation shall not be construed to negate, abridge or otherwise reduce other rights or obligations of indemnity which would otherwise exist as a party or person described in this paragraph.

In claims against any person or entity indemnified under this Agreement by an employee of the Contractor, the Contractor's sub-subcontractors, anyone directly or indirectly employed by them or anyone for whose acts they may be liable, the indemnification obligation under this paragraph shall not be limited by a limitation on amount or type of damages, compensation or benefits payable by or for the Contractor or the Contractor's sub-subcontractors under workers' or workmen's compensation acts, disability benefit acts or other employee benefit acts.

## INSURANCE

A. Contractor's Insurance. Prior to start of the Contractor's work, the Contractor shall procure for the Contractor's work and maintain in force until the completion of the work, workers' compensation insurance, employer's liability insurance, comprehensive general liability insurance and all insurance required of the contract under the contract documents.

The Board of County Road Commissioners of Allegan County Shall Be Named as an Additional Insured on each of these policies except for worker's compensation.

The insurance shall include contractual liability insurance covering the Contractor's obligations under its agreement of indemnification as set forth herein.

B. Minimum Limits of Liability. The Contractor's comprehensive general and automobile liability insurance as required herein, shall be written with limits of liability not less than the following:

a. Comprehensive general liability including completed operations

(1) \$ 1,000,000 each occurrence

b. Property damage

(1) \$ 1,000,000 each occurrence

C. Number of Policies. Comprehensive general liability insurance and other liability insurance may be arranged under a single policy for the full limit required or by combination of underlying policies with the balance provided by an excess or umbrella liability policy.

D. Cancellation, Renewal or Modification. The Contractor shall maintain in effect all insurance coverage required under this Agreement at the Contractor's sole expense and with insurance companies acceptable to the Board of County Road Commissioners of Allegan County.

All insurance policies shall contain a provision that the coverage afforded thereunder shall not be cancelled or not renewed nor restrictive modifications added at any time after a certificate of insurance required under agreement has been issued and before the work; as defined herein, has been completed, until at least thirty (30) days prior thereto written notice has been given to the Board of County Road Commissioners of Allegan County unless otherwise specifically required in the Contract Documents.

Certificates of insurance or certified copies of policies acceptable to the Board of County Road Commissioners of Allegan County shall be filed with the Board of County Road Commissioners of Allegan County prior to the commencement of the Contractor's work.

In the event that the Contractor fails to obtain or maintain any insurance coverage required under this agreement, the Board of County Road Commissioners of Allegan County may:

1. Purchase such coverage and charge the expense thereof to the Contractor, and
2. Withhold from any payment due or to become due to the Contractor an amount sufficient to protect the Board of County Road Commissioners of Allegan County from such claims, damages, demands, payments, suits, actions, recoveries, judgments, losses and expenses, including attorney fees, interest and court costs, and
3. Terminate this agreement.

Nothing contained in this Agreement, nor the Board of County Road Commissioners of Allegan County's compliance therewith, shall relieve the Contractor from its obligations under the Contract to purchase and maintain required insurance or to indemnify the Board of County Road Commissioners of Allegan County.

E. Basis of Award. Each area may be awarded separately, if it is in the best interest of the Road Commission.



ALLEGAN COUNTY ROAD COMMISSION

SPECIAL PROVISIONS

This bid covers the periods from November 1st through April 30 for the 2019-2020, 2020-2021, and 2021-2022, Winter Seasons.

It is understood that the following conditions and requirements apply to and are part of this proposal.

1. Snow shall be removed from the designated streets **WHEN, AND ONLY WHEN**, the order to do so is received from the County Road Commission Maintenance Superintendent or his authorized representative. This may not be for every snowfall. The Road Commission reserves the right to use the contractor based on conditions and availability of county workers. The Road Commission may only call out part of the designated streets at their discretion.

2. Snow shall be removed from the designated streets by means of a displacement plow to a cleared width of not less than 26 feet (20 feet of paved surface plus 2 shoulders at 3 feet wide each) Exceptions to this requirement will be roads lacking sufficient width. These widths must be maintained through the entire winter season with additional equipment if necessary.

3. The bidder shall commence snow removal operations within two (2) hours of notification by the designated Road Commission employee and proceed with the work continuously until all of the required streets are cleared of snow. Streets included in this awarded contract are to be cleared of snow within fourteen (14) hours of notification by the Road Commission.

4. All equipment shall be operated only by licensed, experienced, competent and careful operators and said equipment will be maintained in good repair and operating condition and will be fitted with all appropriate lighting, sounding and other safety equipment required by Road Commission and/or by law to prevent injury to persons or property.

5. The basic equipment to be used in the performance of this work shall be:

- (1) A front-mounted displacement type plow
- (2) An underbody scraper blade.

A list of the vehicle(s) and equipment to be used shall be listed within this proposal. Only equipment approved by the Road Commission shall be used for this work.

6. The bidder agrees that he will promptly and properly resolve any complaint from property owners or the Road Commission in regard to damage to mailboxes, vehicles, trees or other property which arise out of the performance of this work.

7. This contract may be extended in one year increments, up to four (4) additional years upon mutual agreement of the Allegan County Road Commission and the contractor each year.

Equipment to be used in the performance of this bid:

Equipment Description

- 1. \_\_\_\_\_
- 2. \_\_\_\_\_
- 3. \_\_\_\_\_
- 4. \_\_\_\_\_
- 5. \_\_\_\_\_
- 6. \_\_\_\_\_
- 7. \_\_\_\_\_
- 8. \_\_\_\_\_
- 9. \_\_\_\_\_
- 10. \_\_\_\_\_
- 11. \_\_\_\_\_
- 12. \_\_\_\_\_

OTSEGO TOWNSHIP

<u>MAP</u>	<u>MILES</u>
Map 1A.....	0.78
Map 2A.....	1.76
Map 4A.....	0.23
Map 5A.....	0.75
Map 6A.....	0.51
Map 7A.....	0.70
Map 8A.....	0.43
Map 9A.....	0.50
Map 10A.....	2.30
Map 11A.....	<u>0.28</u>
SUBTOTAL	8.24

GUN PLAIN TOWNSHIP

<u>MAP</u>	<u>MILES</u>
Map 1B.....	0.44
Map 2B.....	0.50
Map 3B.....	0.66
Map 4B.....	1.13
Map 5B.....	5.68
Map 6B.....	0.63
Map 7B.....	0.82
Map 8B.....	0.41
Map 9B.....	0.61
Map 10B.....	<u>0.13</u>
SUBTOTAL	11.01

Total Miles to be plowed.....19.25

NOTE: Roads shown in solid black on the maps are not included in the total and are not to be plowed (except the Lake Doster area map).

We will plow the above described roads in Otsego Township totaling 8.24 miles at a unit price of \$ \_\_\_\_\_ per mile per time and in Gun Plain Township totaling 11.01 miles at a unit price of \$ \_\_\_\_\_ per mile per time for a total bid price of \$ \_\_\_\_\_ for one plowing.

SIGNED: \_\_\_\_\_  
Bidder

DATE OF BID \_\_\_\_\_

106TH. AVE.

KALA

Sheridan

Sherman

660

Nicholson

Allegran

89

SON ROAD

407'

323'

OTSEGO Orleans

323'

20'

Franklin

17'

660'

Muriel

INT. 1/4 POST  
SEC. 22

18TH. ST.

T 1 N R 12 W

104TH. AVE.

OTSEGO 1-A

0.78 MILES

NO. 2 (1977)  
 (2003)  
 2003  
 2003

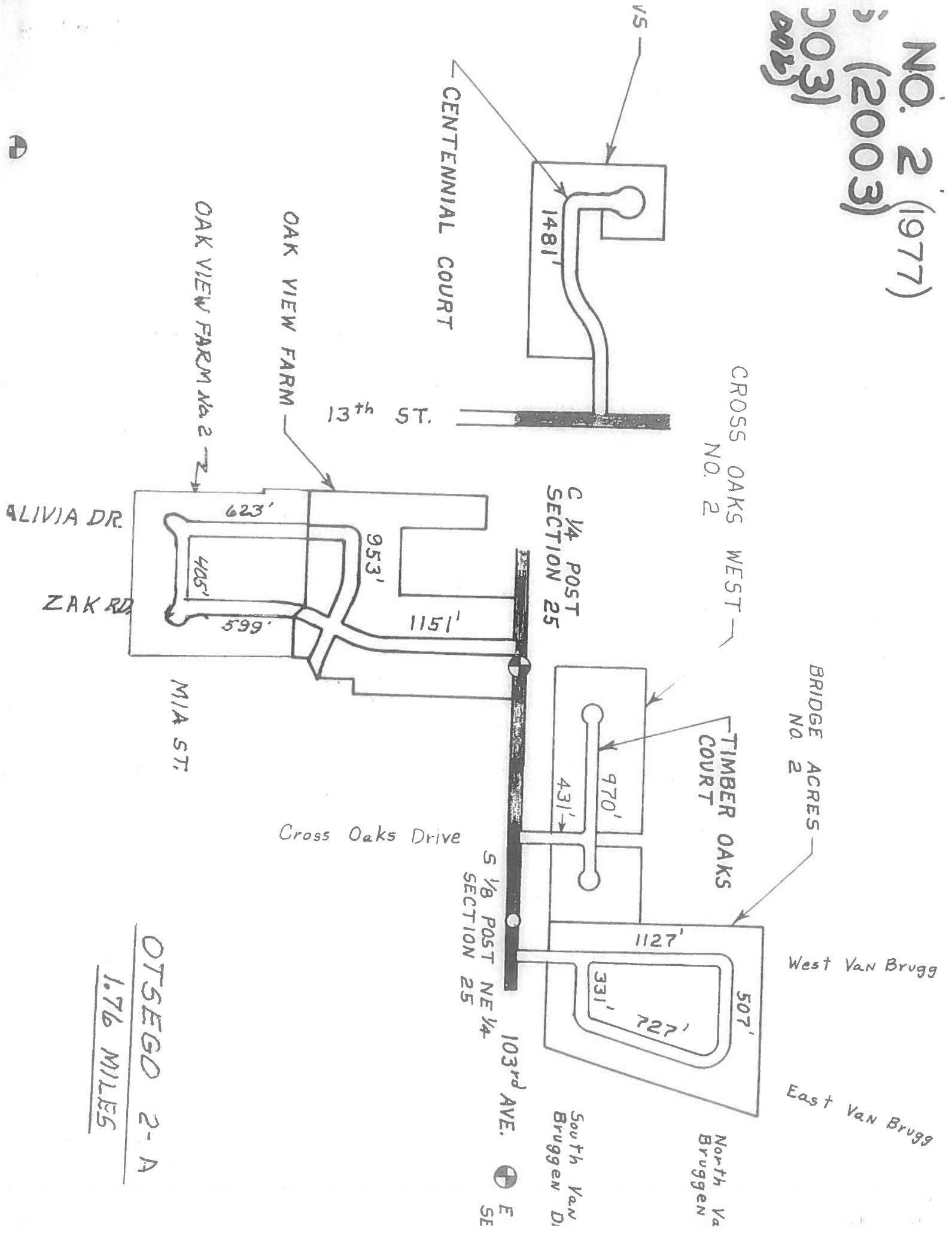

OTSEGO 2-A  
 1.76 MILES



6

-W  
S (1970)

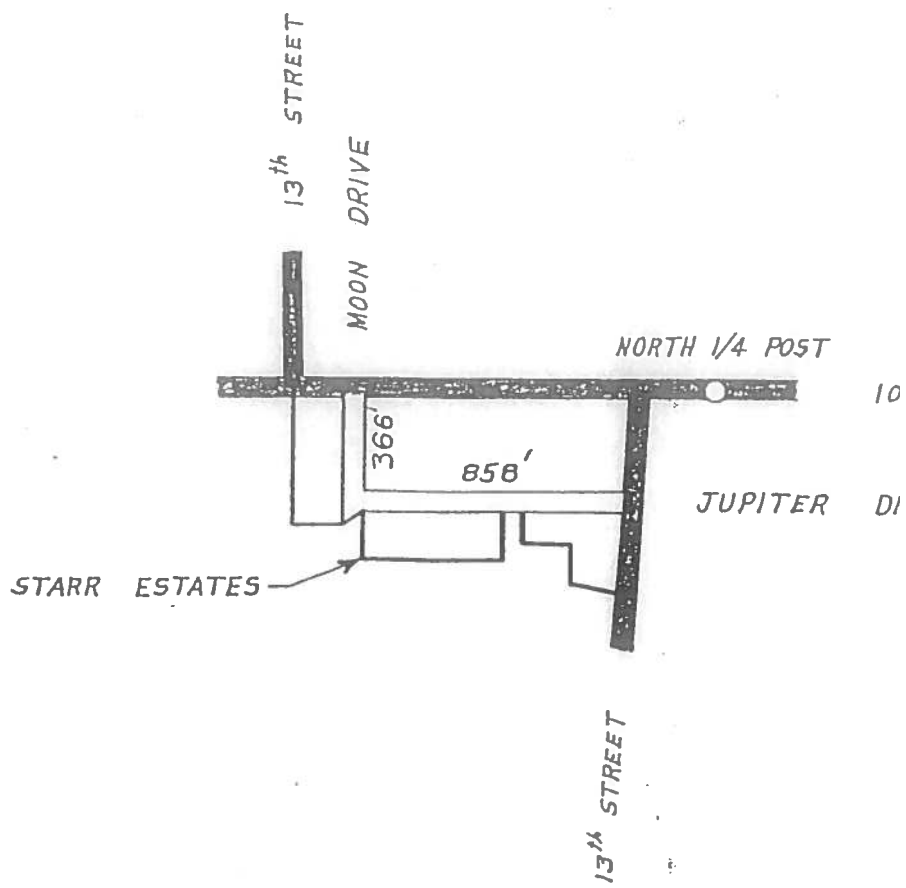

OTSEGO 4-A  
0.23 MILE

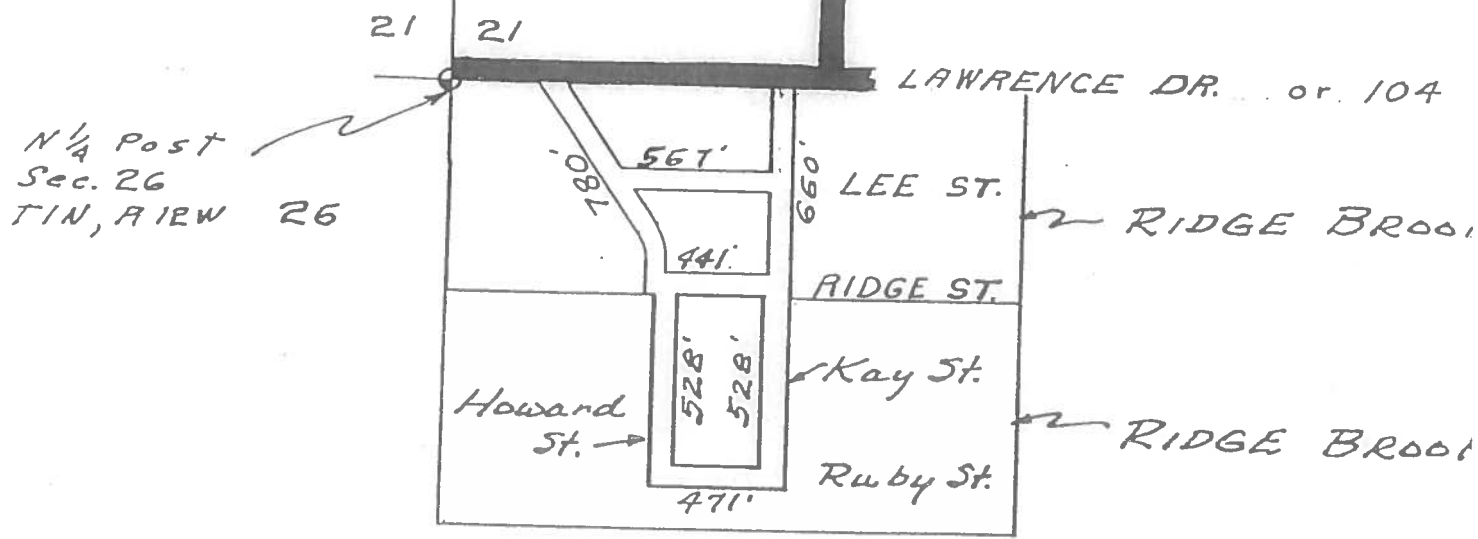

OTSEGO 5-A  
0.75 MILE

INSHIP

R12W

PLAT

GROVE PLAT

13th St.

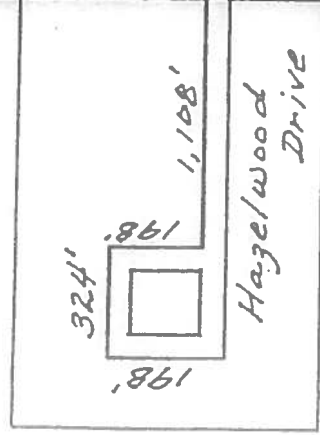

Colegrove Plat

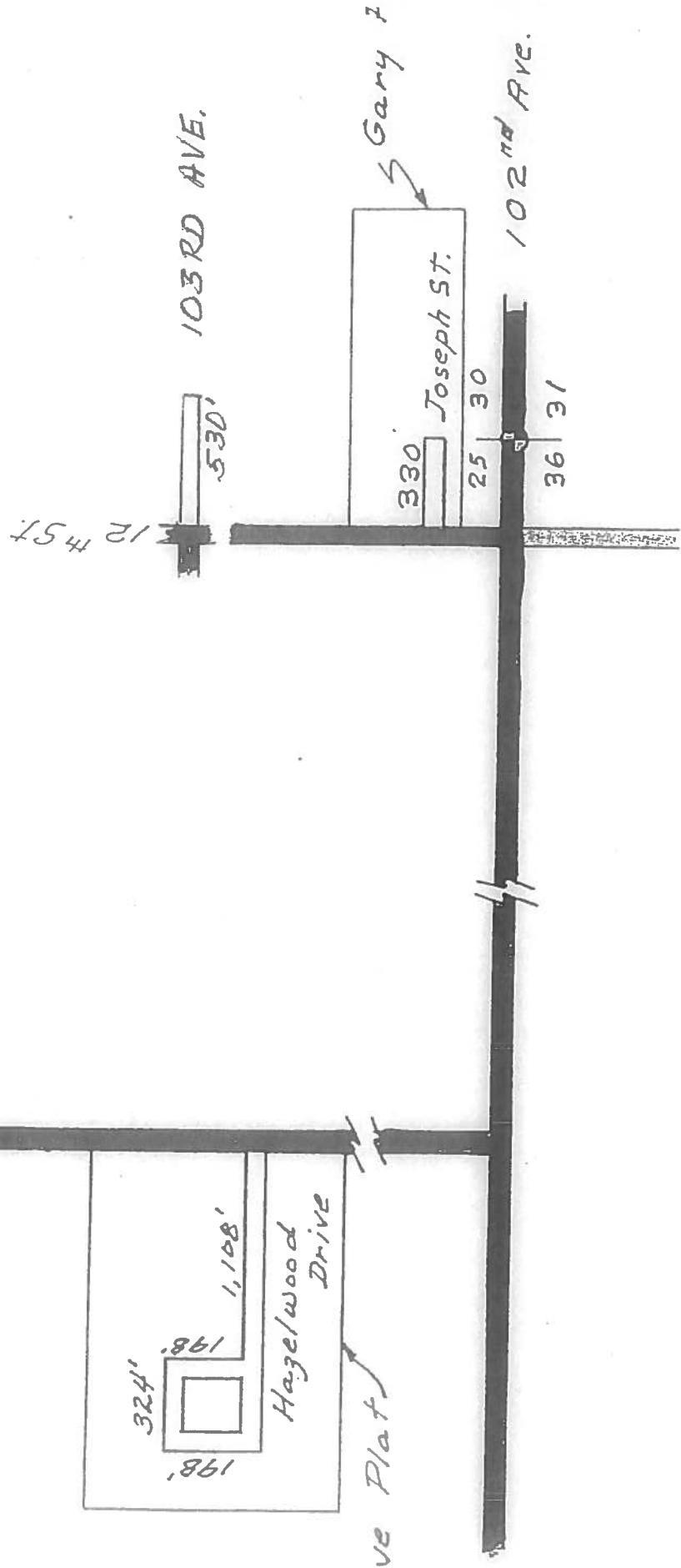

0.4/miles

OTSEGO 6-A

0.51 ~~0.51~~ MILE



10R

T

JOR NO. 2 (1978)

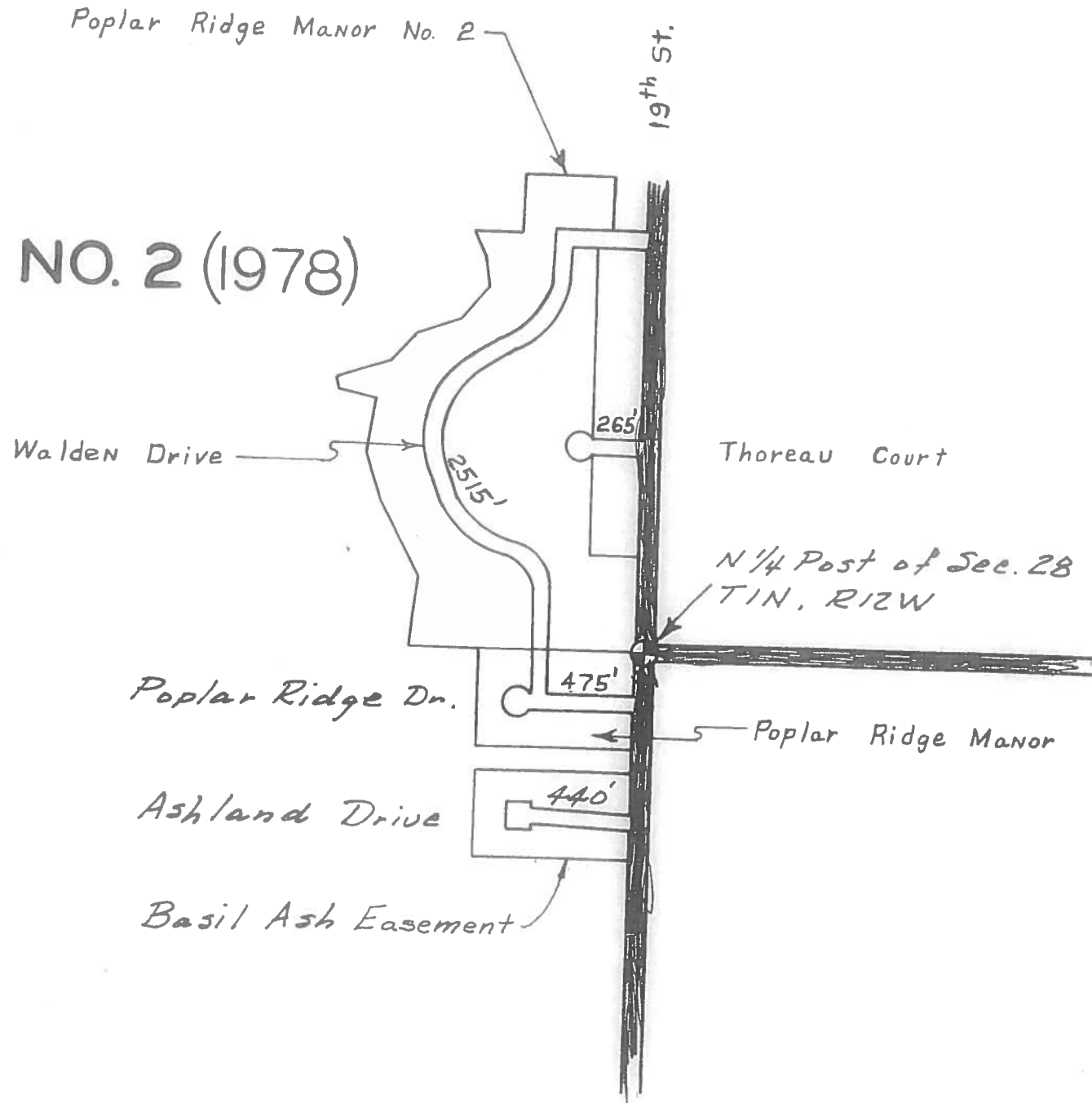

OTSEGO 7-A  
0.70 MILE

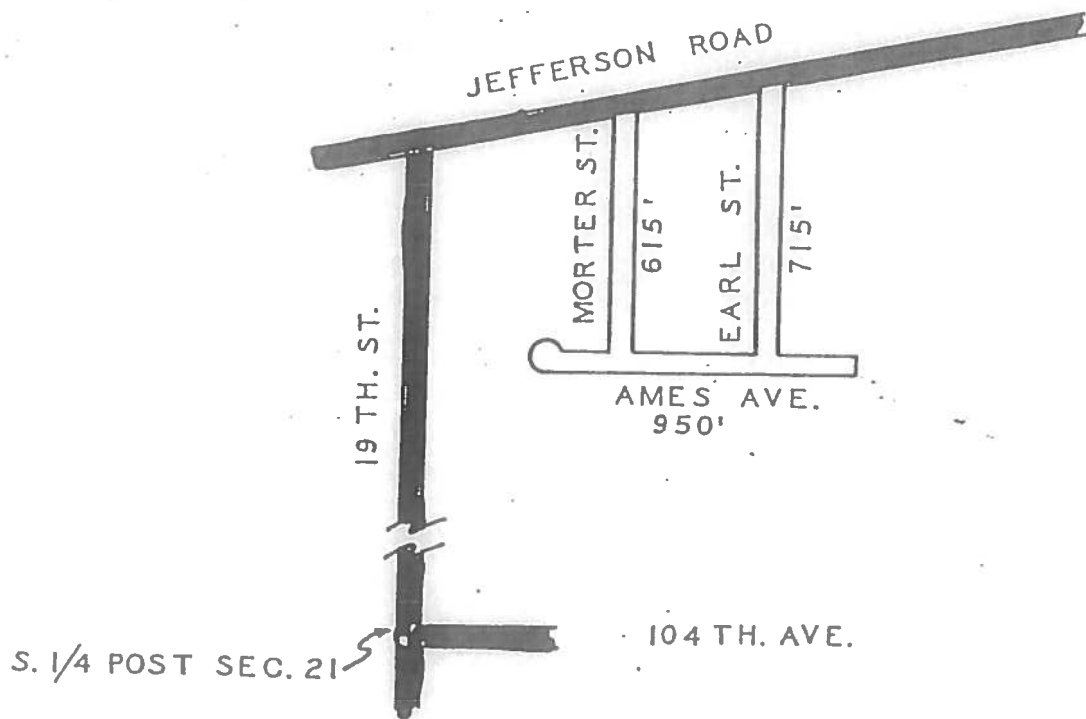

OTSEGO 8-A

0.43 MILE

ES

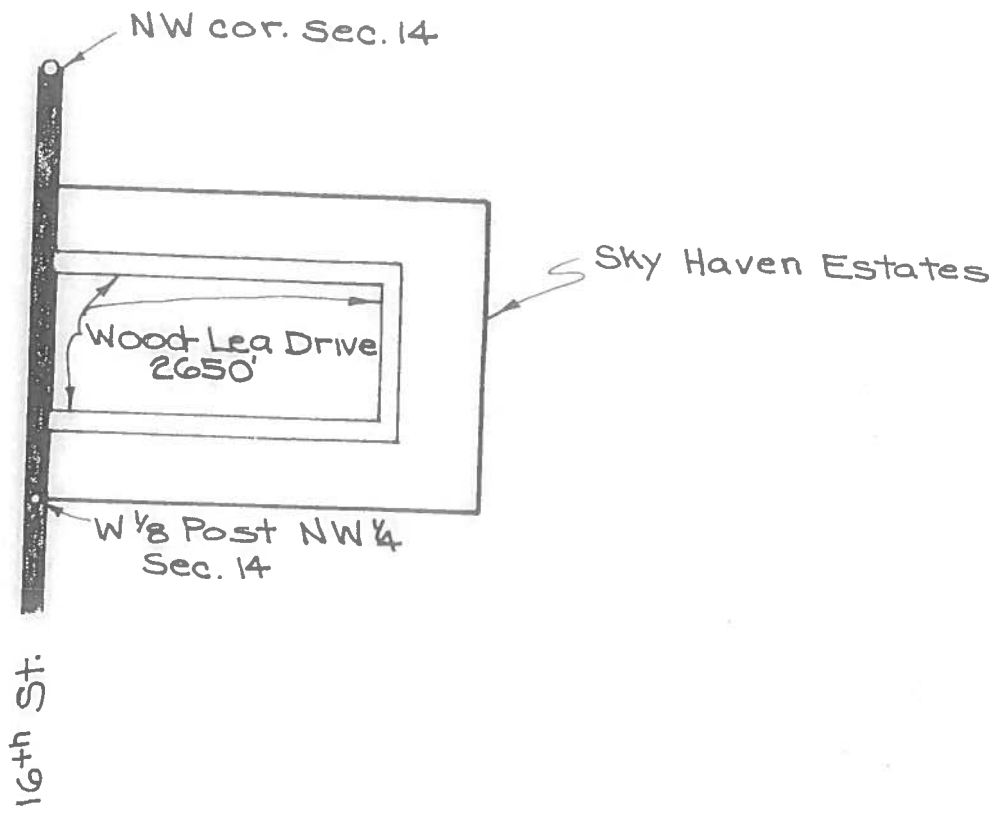

OTSEGO 9A  
0.50 MILES

Scale: 1" = 600'

T

NO. 1

BRIARWOOD ST.

TANGLEWOOD I

SPRINGBROOK DI

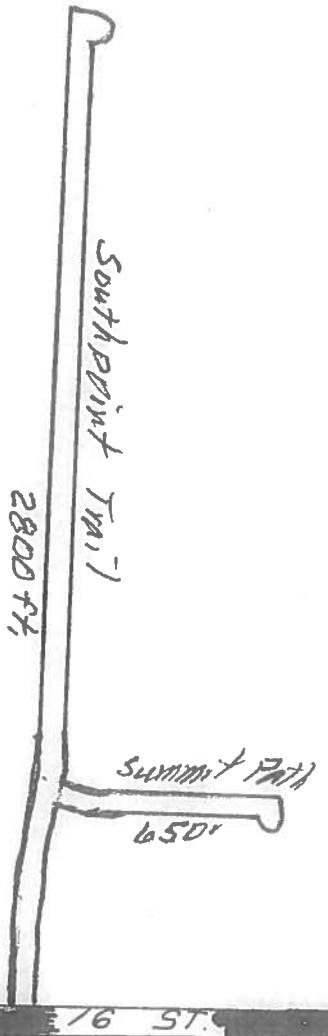
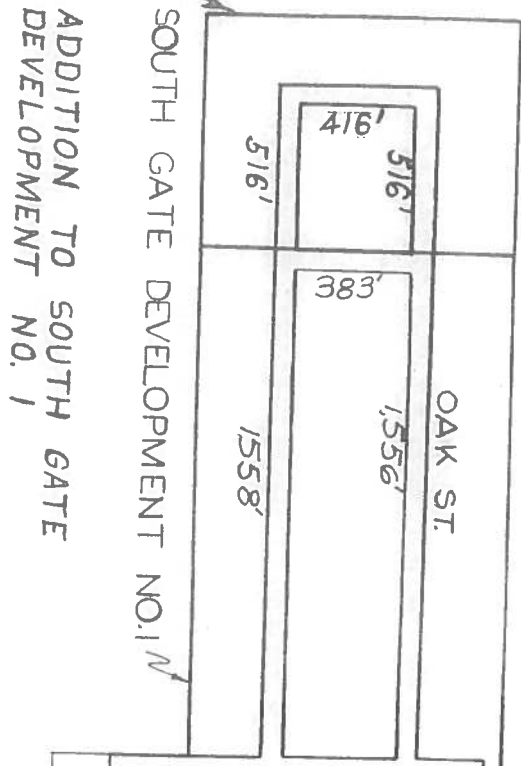

22  
27  
26  
23  
NE Cor. Sec. 27  
T1N, R12W

P.O.B. 40' W & 621'S  
of NE Cor. of Sec. 27  
T1N, R12W

OTSEGO 10\_A  
2.30 MILES

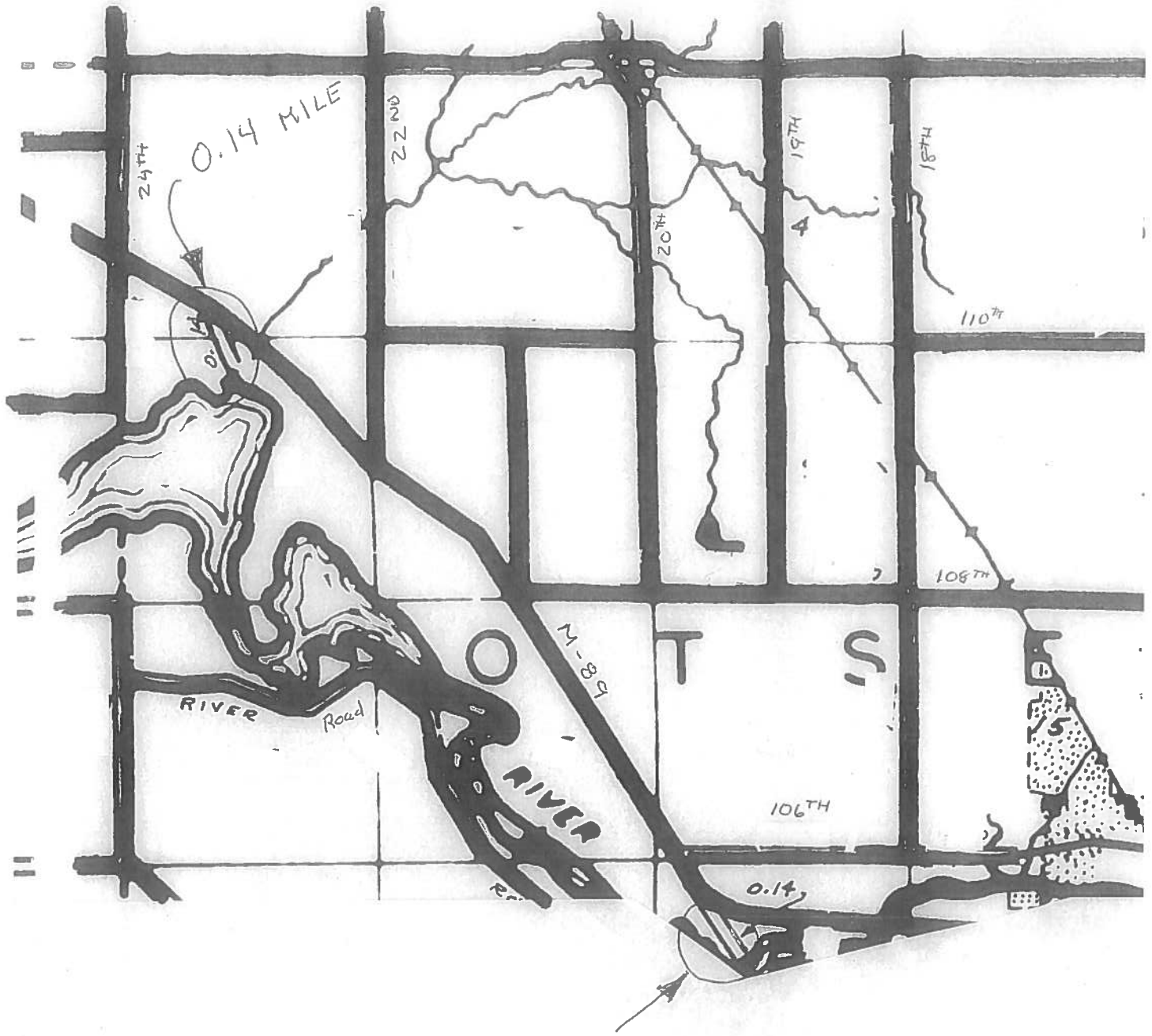

0.14 MILE

OTSEGO II A  
0.28 MILES

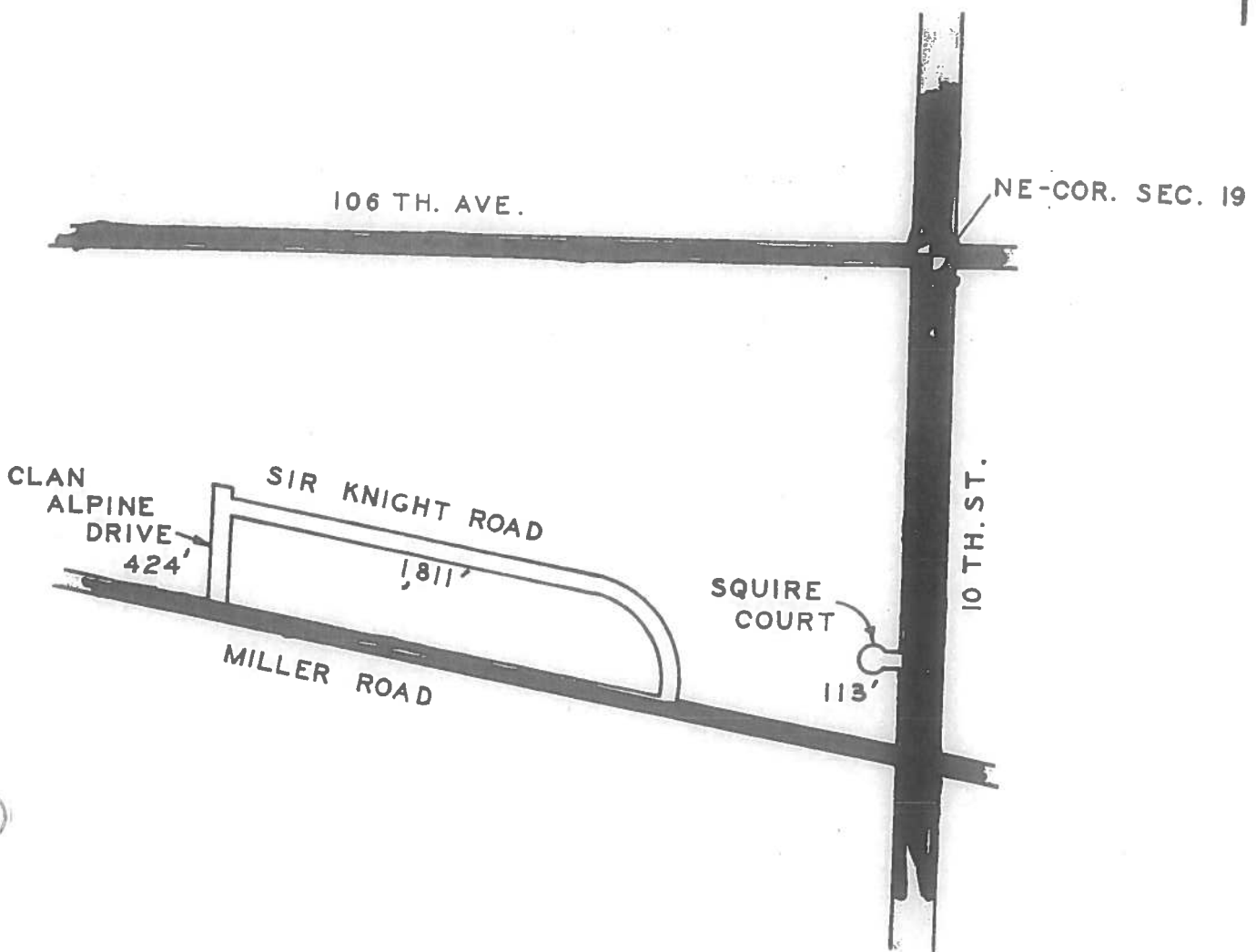

PLAINWELL 1-B  
0.44 MILE



1969)

NO. 2 (1970)

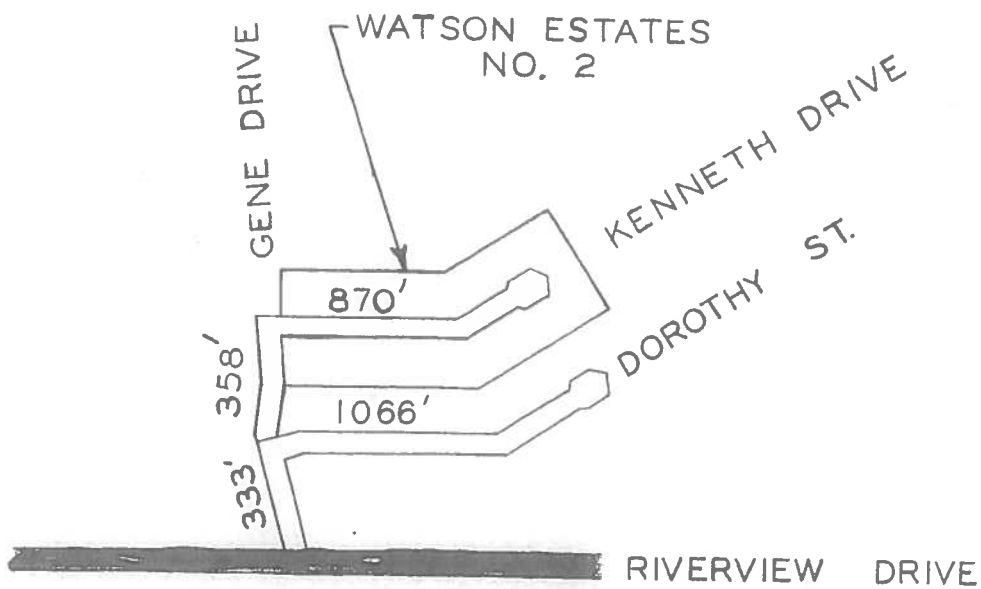

PLAINWELL 2-B  
0.50 MILE

⊕ W 1/4 POST SECTION 27

⊕ C SE

6th STREET

NICOLE COURT

Miles

RUSHING DRIVE

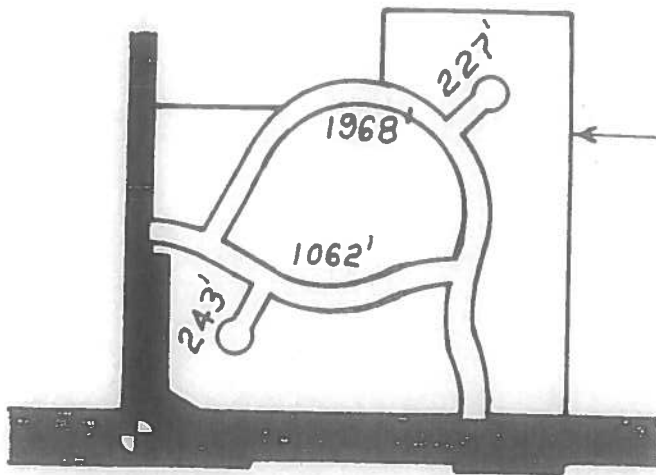

HYDER MEADOWS

M-89

⊕ S SE

SW SECTION CORNER OF 27

ANNIS COURT

HYDER CIRCLE DRIVE

PLAINWELL 3-B

0.66 MILE

1" = 600'



TOP VIEW

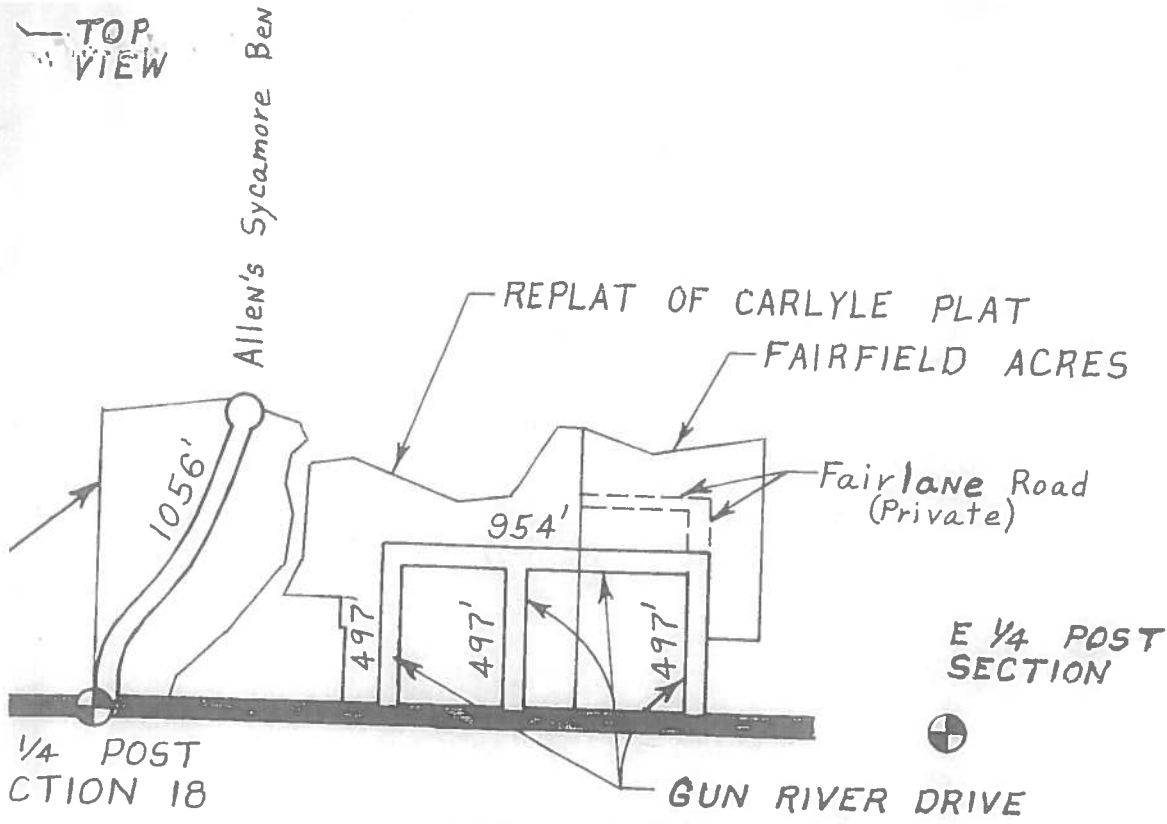

1/4 POST SECTION 18

E 1/4 POST SECTION

ALLEN COURT

TAYLOR LANE

PARK PLAT

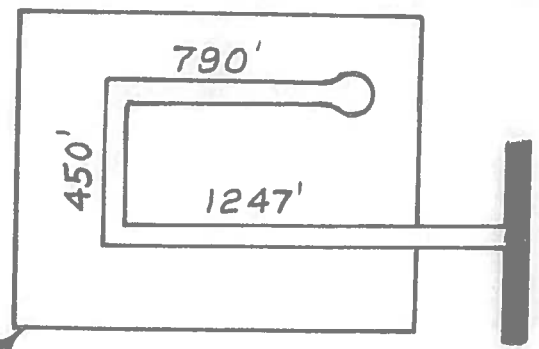

EDWARD DRIVE

10th ST.

1/4 POST SECTION 18

SE SECTION CORNER OF 18

PLAINWELL 4-B  
1.13 MILES

GUN PLAIN 4-H

# Lake Doster Area Map

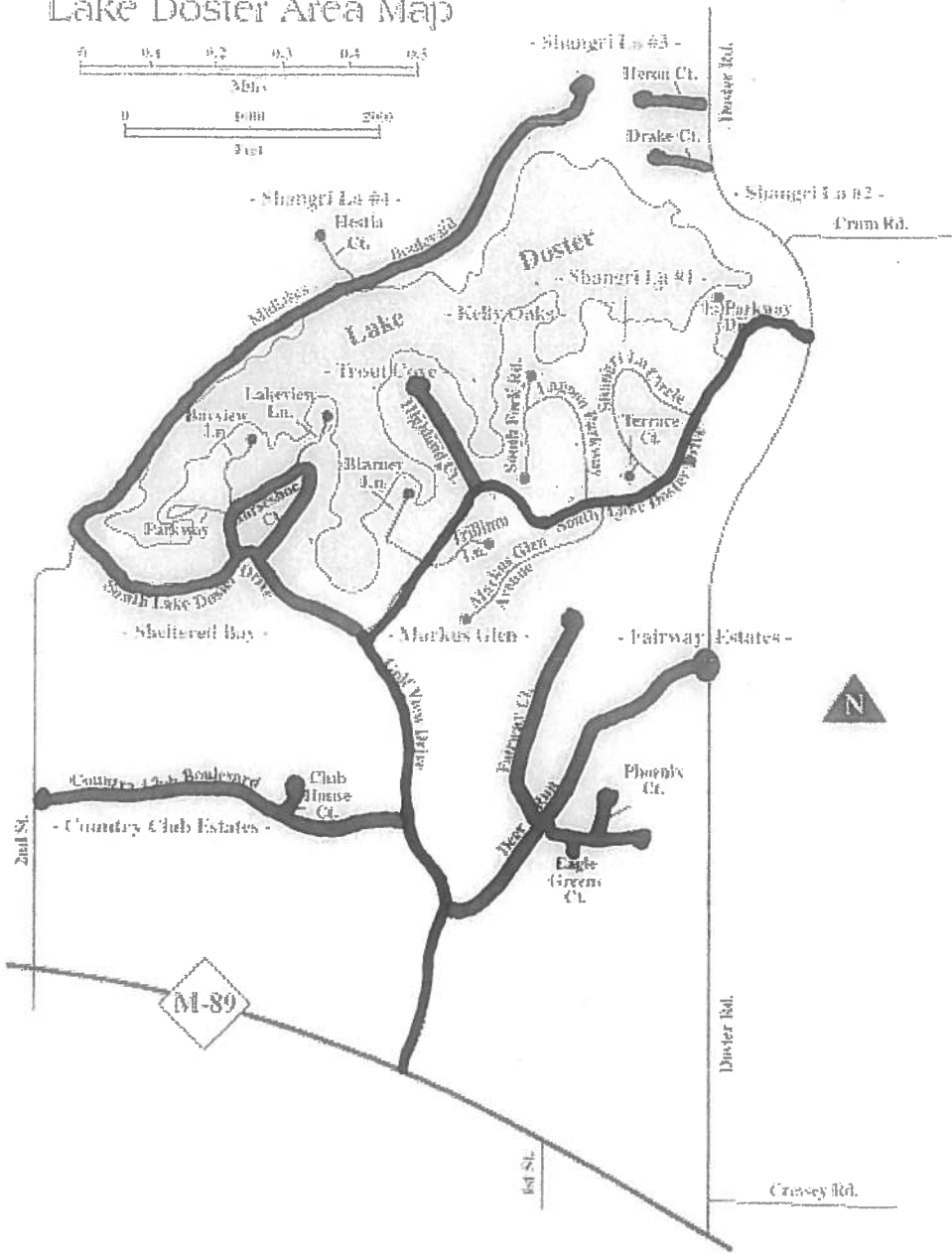

PLAINWELL 5-B  
5.68 MILES

Roads Shown Dark Black Only

ON 8

PLAIN  
NSHIP  
R-II-W  
AND MORRISON  
'S PLAT (1970)

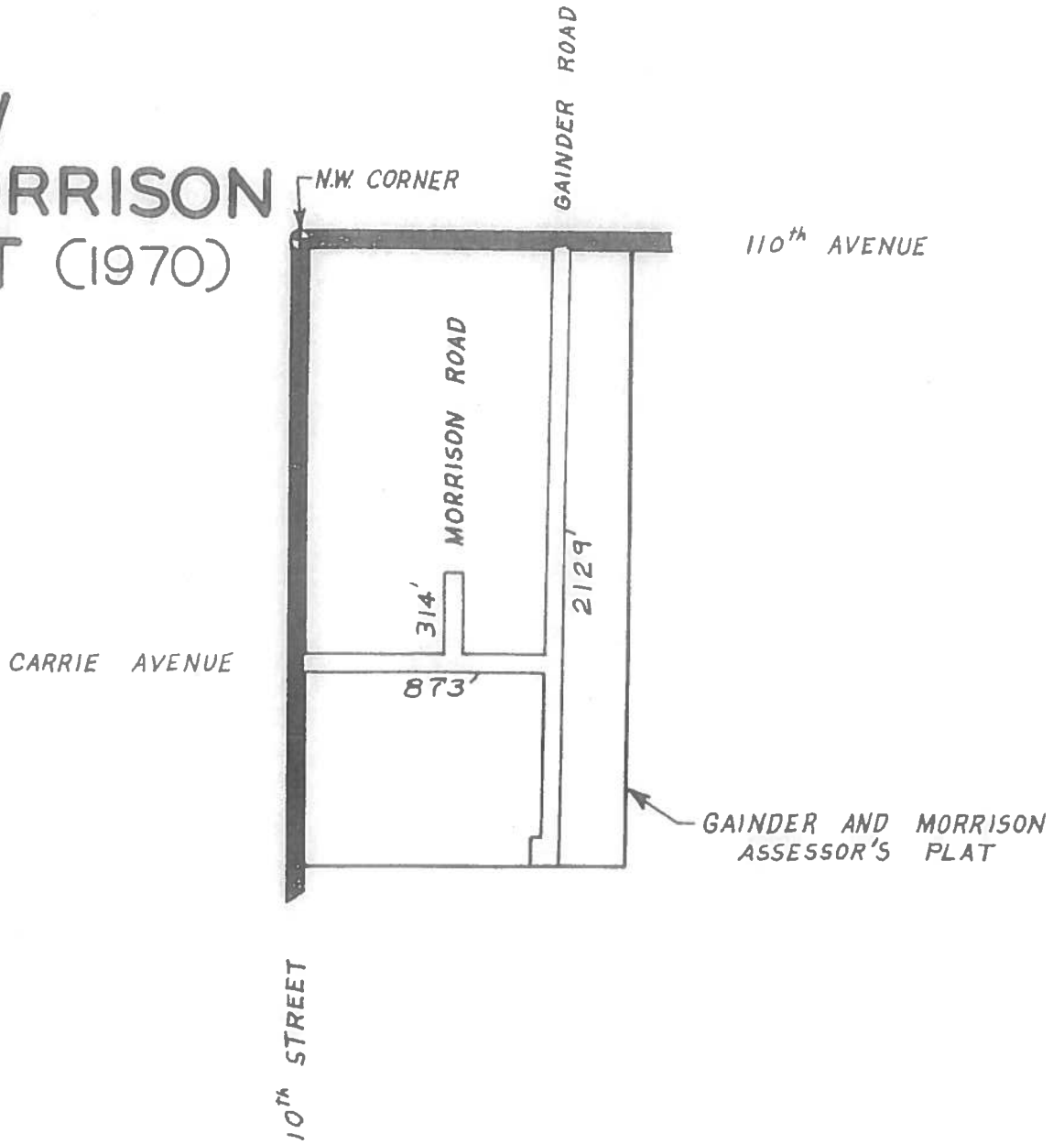

MI.

GUN PLAIN 6B.

0.63 MILES

8th St.

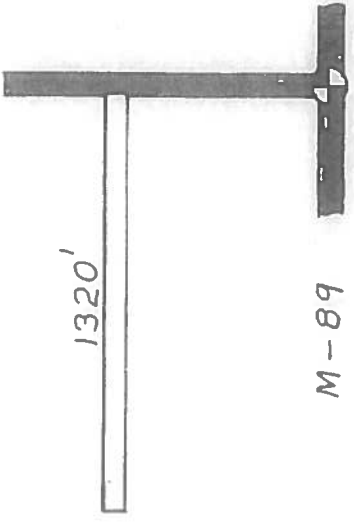

2nd Division St.

E 1/4 POST  
SECTION 29

M-89

C 1/4 POST  
SECTION 29

GUN PLAIN 7B

0.82 MILES

SE SECTION  
CORNER OF 29

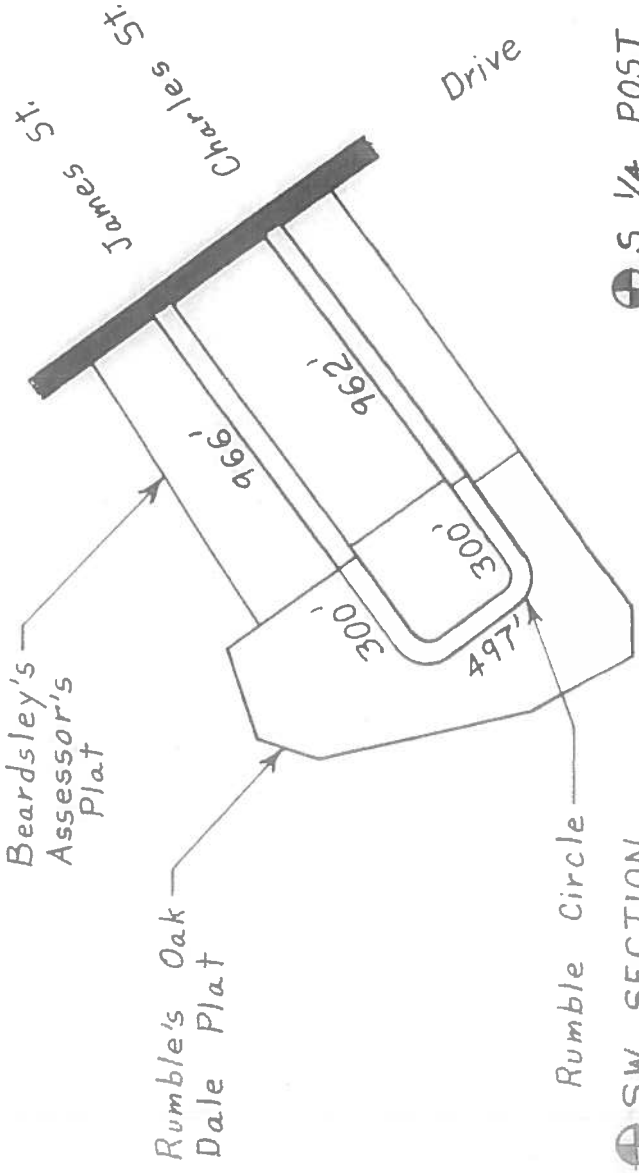

S 1/4 POST  
SECTION 29

SW SECTION  
CORNER OF 29



NW SECTION  
CORNER OF 18



N 1/8 POST  
OF NW 1/4  
108<sup>th</sup> AVE.

TOP VIEW DRIVE

AUTUMN DRIVE

N 1/4 POST  
SECTION 18

686'

1238'

265'

TOP  
VIEW

34)  
74)

T (1999)

11<sup>th</sup> ST.

AUTUMN COURT

~~Allen's Steamers Road~~

~~SKAMORE BLVD~~

1056'

497'

497'

W 1/4 POST  
SECTION 18

107<sup>th</sup> Ave.

~~1/4 POST  
SECTION 18~~

GUN PLAIN 8B

0.41 MILES

~~ALLEN COURT~~

~~TAYLOR LANE~~

~~AIRPORT PARK PLAT~~

SW SECTION

~~1/4 POST~~

~~102 ND.~~

102<sup>ND</sup>

AVE.

JERSEY ST.

(GORE'S  
Addition)

ELMWOOD AVE.

586.85'

BLOOMFIELD AVE.

586.29'

BRONSON AVE.

750.57'

U.S. 131

LIBERTY ST. 1283'

ST.

11TH

GUN PLAIN 9B

0.61 MILES

ION 5  
PLAIN  
SHIP  
N R-11-W  
PLAT (2001)

NW SECTION  
CORNER OF 5

PAULA ST.

N  
S

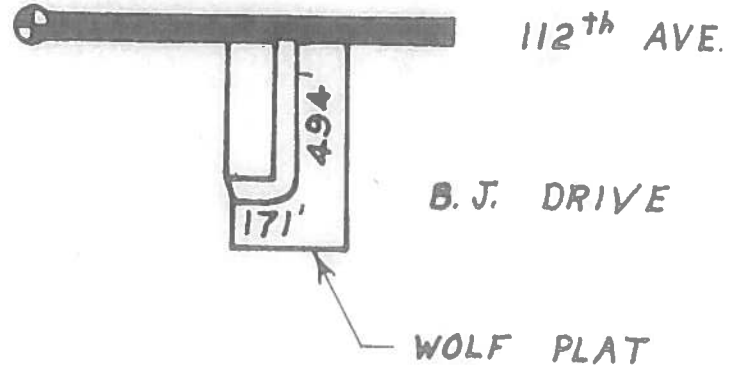

W 1/4 POST  
SECTION 5

C  
S



GUN PLAIN 10B

0.13 MILES

= 0.12 Miles